

Workshop manual
226R RJ RS

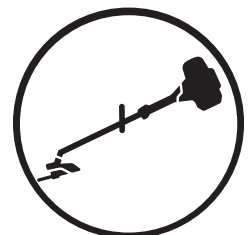

English

Workshop Manual

Brushcutter, Trimmer

Model 226R

Contents

General recommendations _____	2
1. Starter _____	3
2. Electrical system _____	7
3. Fuel system _____	13
4. Centrifugal clutch _____	25
5. Angle gear _____	31
6. Cylinder and piston _____	35
7. Crankshaft and crankcase _____	45
8. Tools _____	51
9. Technical Data _____	55



© Husqvarna AB, Sweden 2009

General recommendations

The workshop used to carry out repairs must be equipped with safety devices in accordance with local directives.

No one may carry out repairs without first having read and understood the contents of this Workshop Manual.

The boxes below can be found in appropriate parts of this manual.



WARNING!

The warning box warns of the risk for personal injury if the instructions are not followed.

NOTE!

This box warns of damage to material if the instructions are not followed.

The machine is type approved for safety in accordance with applicable legislative demands with the equipment specified in the Operator's Manual. The assembly of other equipment or accessories or spare parts not approved by Husqvarna can result in the failure to meet these safety demands and that the person carrying out assembly bears responsibility for this.

Bear in mind:

- ⚠ Do not start the engine without the clutch drum and driveline fitted as the clutch can become detached and cause severe personal injury.
- ⚠ Do not touch hot components, e.g. the muffler and clutch before they have cooled sufficiently to avoid burns.
- ⚠ Avoid getting fuel or oil on your skin or in your mouth. Use a barrier cream on your hands. This reduces the risk of infection and makes dirt easier to wash away. Long term contact with engine oil can represent a health hazard.
- ⚠ Never start the engine indoors. Exhaust fumes are poisonous!
- ⚠ Wipe up oil spills from the floor immediately to avoid slipping.
- ⚠ Do not use tools that are worn or fit badly, for example on nuts and bolts.
- + Always work on a clean bench.
- + Always work logically to ensure all parts are fitted correctly and that nuts and bolts are tightened.
- + Use the special tools where recommended to be able to carry out the work correctly and efficiently.

Fire risk

Handle fuel with respect as it is extremely inflammable.

Do not smoke and ensure there are no open flames or sparks in the vicinity.

Make sure there is a working fire extinguisher close at hand.

Do not try to extinguish a petrol fire with water.

Poisonous fumes

When using cleaning agents read the instructions carefully.

Ensure there is good ventilation when handling petrol and other volatile fluids.

The engine's exhaust fumes are poisonous. Test run the engine outdoors.

Special tools

Some of the work described in the Workshop Manual requires special tools. In each section where this is necessary there is a picture of the tool and an order number.

We recommend the use of special tools in order to avoid expensive damage to parts in question and personal injury and to provide an efficient repair procedure.

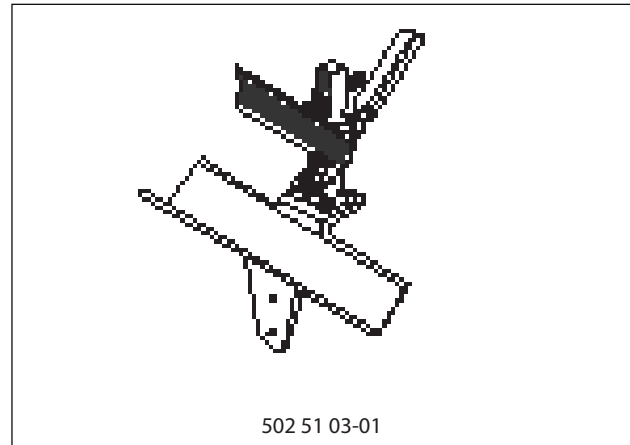

Contact faces and gaskets

Ensure all surfaces are clean and free from gasket residue, etc. When cleaning use a tool that will not damage the contact face. Any scratches or unevenness should be removed using a flat fine cut file.

Sealing rings

Always replace a sealing ring that has been dismantled. The sensitive sealing lip can easily be damaged resulting in inferior sealing capacity. Surfaces which the seal shall seal against must also be completely undamaged. Lubricate the sealing lip with grease before it is fitted and ensure that it is not damaged e.g. by shoulders and splines on a shaft. Use tape or a conical sleeve as protection. It is important that the sealing ring faces in the right direction for it to act as it is intended.

Starter

1

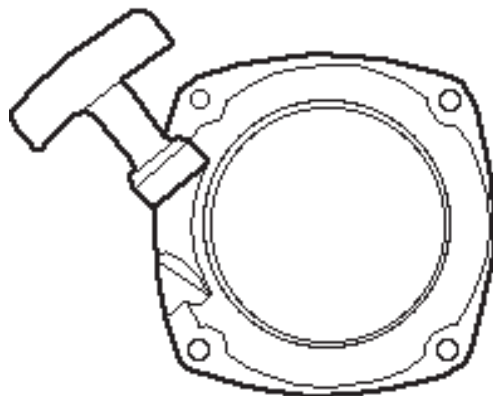

Contents

Dismantling	4
Assembly	5
Replacing the drive	6

**WARNING!**

Protective glasses should be worn when working on the starter to avoid injury to the eyes if, for some reason, the return spring should fly out.

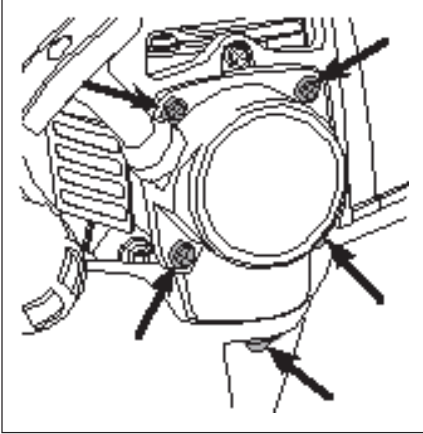
**Dismantling**

Remove the 5 bolts and lift off the starter.

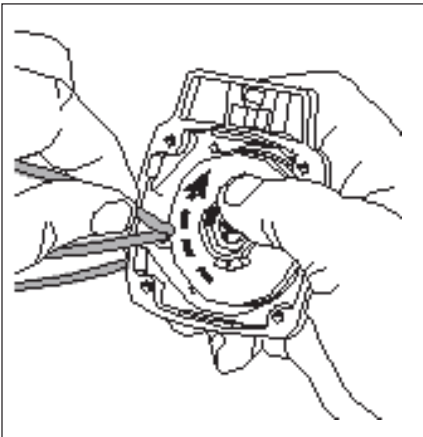

Loosen the spring tension.

Lift up the starter cord on the starter pulley and allow it to rotate backwards until the spring tension ceases

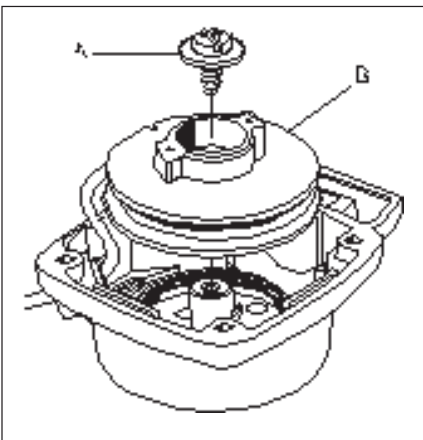

Dismantle the screw holding the starter pulley.

Carefully lift off the starter pulley so that the return spring does not fly away.

Dismantling

Remove the 5 bolts and lift off the starter.

Loosen the spring tension.

Pull out the starter cord about 30 cm.

Slow the starter pulley with your thumb.

Lift the starter cord up out of the cut-out on the starter pulley.

Let the starter pulley rotate backwards until the spring tension ceases.

**WARNING!**

Be careful not to injure your thumb when the starter pulley rotates in reverse.

Dismantle the screw (A) in the centre of the starter pulley.

Carefully lift away the starter pulley (B).

**WARNING!**

Wear protective glasses.

The return spring lies tensioned in the starter housing and can fly out and cause personal injury with careless handling.

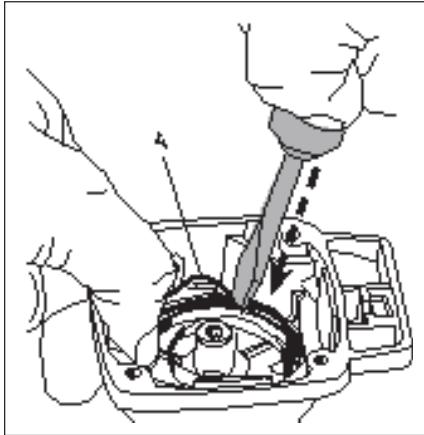

Assembly

Fit the return spring in the starter housing.

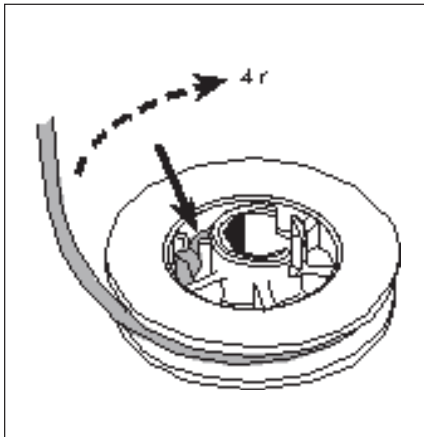

Assemble a new starter cord and wind it 4 turns clockwise around the starter pulley.

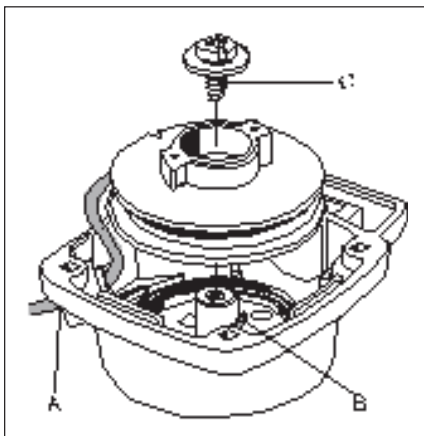

Lubricate the return spring and position the starter pulley.

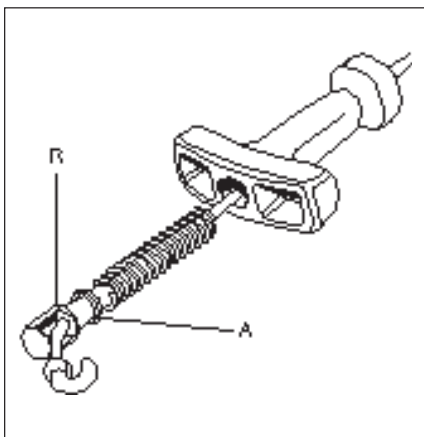

Fit the starter handle.

Assembly

If the return spring has, despite all the precautions, flown out or if you intend to fit a new spring proceed as follows:

1. The spring lies tensioned with a sturdy steel wire in shrink wrap.
Cut the package open very carefully in order to prevent the spring from popping out.
2. Position the spring in the starter housing.
3. Keep the spring in place using one of your thumbs.
4. Use a screwdriver to first push the spring down by its attachment in the starter housing and then on the diametrically opposed side so that the steel wire (A) glides off of the spring.

Attach the new starter cord.

Ensure that the knot is as small as possible and enters the cut-out on the starter pulley.

Wind the cord 4 turns clockwise around the starter pulley.

Lubricate the return spring and the starter pulley's stub axle with cold resistant grease or thin oil.

Move the starter cord through the guide in the starter housing (A).

Guide the free end of the return spring (B) in towards the cut-out in the hub of the starter pulley and slide the starter pulley down into the starter housing.

Fit the screw (C).

Fit the starter handle on the cord.

Thread the starter cord through the handle, spring, support washer (A) and guiding sleeve (B).

Tie a small knot in the starter cord and pull it into the guiding sleeve.

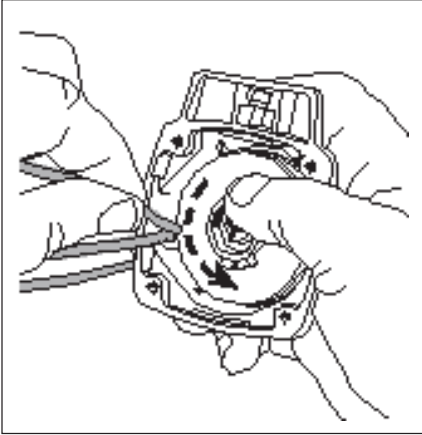

Tighten the return spring.
Check the spring tension.

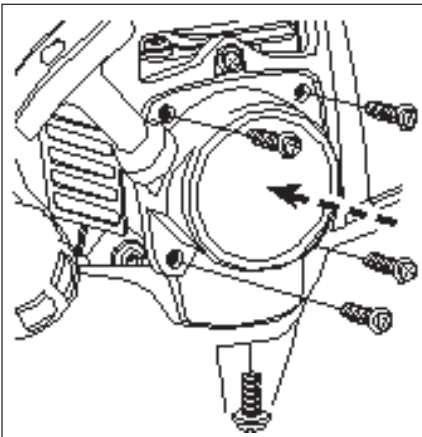

Fit the starter.

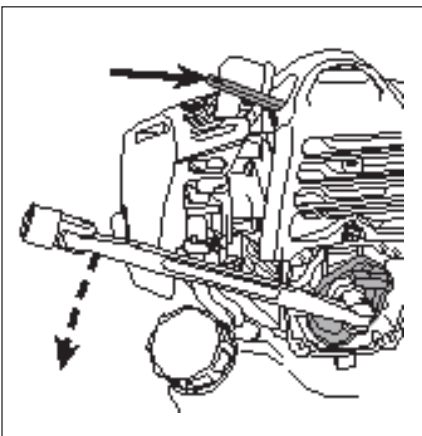

Replacing the drive

Dismantle the drive disc anticlockwise.

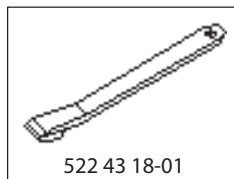

522 43 18-01

Replace the drive dog if it is worn or defective.

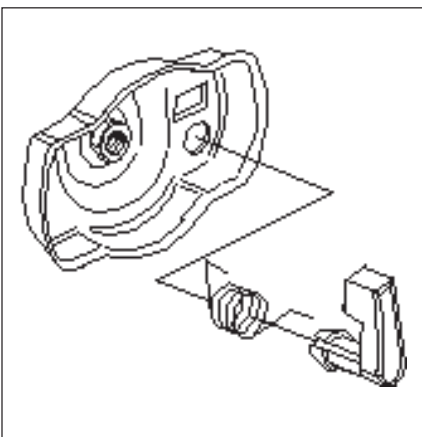

Tighten the return spring.

Pull out the starter cord completely and slow the starter pulley with your thumb.
Lift the starter cord up out of the cut-out on starter pulley.

Then turn the starter pulley anti-clockwise 5 revolutions.

Check the spring tension. With the cord completely pulled out the cord pulley should be able to be turned at least another half revolution.

Fit the starter on the engine body.

Hold the starter in place and tighten the 5 screws.

Check that the starter works.

Replacing the drive

The drive disc is threaded on the crankshaft.

To remove it, stop the engine from rotating by using the piston stop no. 522 43 18-01. Note that it must be placed on top of the piston in the combustion chamber.

Loosen the drive disc in an anticlockwise direction.

NOTE!

The nut is soldered onto the drive disc.

Replace the drive dog if it is worn or defective.

Clamp the blades of the drive dog together with a pair of pliers and push it out from the drive disc cup.

Electrical system

2

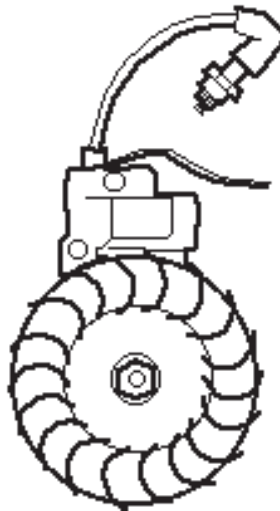

Contents

Checking the ignition spark	8
Dismantling	10
Assembly	11

The engine is equipped with an electronic ignition system completely without moving parts. Consequently, a faulty component cannot be repaired, but must be replaced by a new component.

The spark in an electronic ignition system has a very short burn time and can therefore be interpreted as weak and can be difficult to see while troubleshooting.

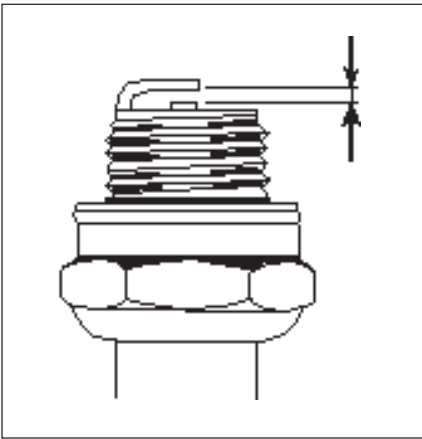

Checking the ignition spark

Clean the electrodes and check the electrode gap.

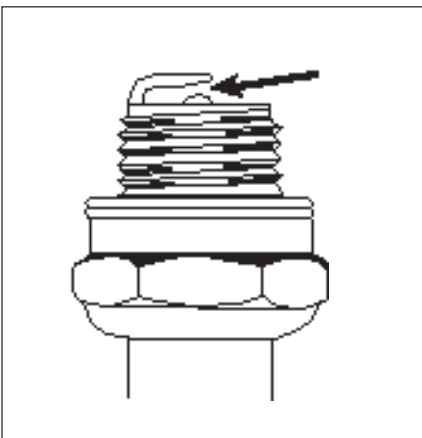

If the electrodes are worn more than 50% the spark plug should be changed.

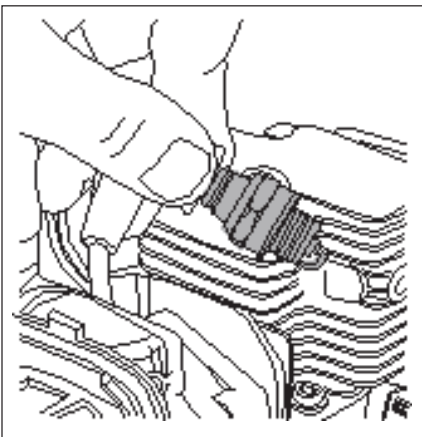

Check if a spark occurs when attempting to start.

Test with test spark plug no. 502 71 13-01 if no spark is seen.



502 71 13-01

Checking the ignition spark

Remove the spark plug and clean it from soot deposits with the help of a steel brush.

Check the electrode gap. It should be 0.6 mm.

Adjust the gap as needed to the correct value with the side electrode.

If the electrodes are worn more than 50% the spark plug should be changed.

Too large a spark gap entails a great deal of stress on the ignition module and risk for short-circuiting.

Also check that the stop switch is in the start position.

Dismantle the carburettor cover and the cylinder cover.

Earth the spark plug on the cylinder and pull sharply on the start handle.

A spark should be seen between the electrodes.

If no spark is seen test with test spark plug no. 502 71 13-01.

If a spark then occurs, the spark plug is faulty.

Try a new spark plug.



If there is still no spark the fault may be either in the stop switch or in the short-circuit cable.
Replace any faulty parts.

If there is still no spark, disconnect the short-circuit cable.
If the plug now sparks, the fault is either in the stop switch or the short-circuit cable.
Replace any faulty parts.
To replace a stop switch, see "Throttle" in chapter 3 "Fuel system".

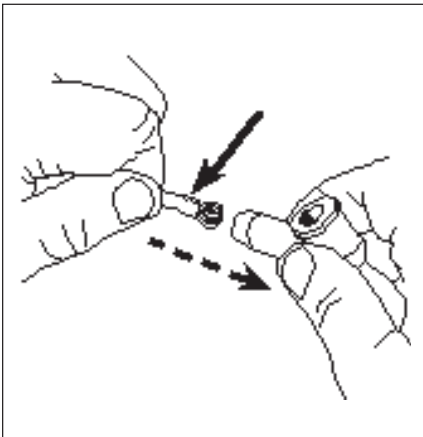

Still no spark?
Check the ignition cable's connection to the spark plug cover.

Still no spark?
Check the spark plug connection.
Remove the spark plug cover and make sure the ignition cable is not damaged.
Remove a segment of cable if required to get sufficient contact at the connection coil.

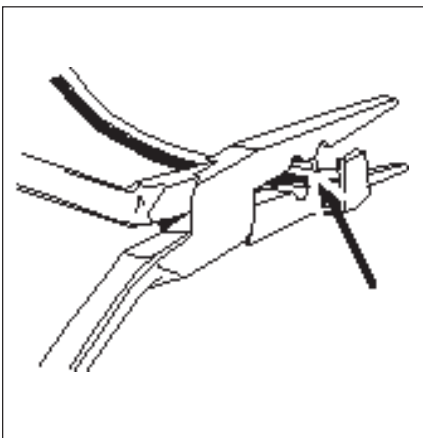

Use pliers no. 502 50 06-01 to make a new hole in the ignition lead once a piece of the damaged lead has been cut off.

When a part of the ignition lead has been cut off it helps to use pliers no. 502 50 06-01 to make a new hole in the ignition lead to fit the contact coil.

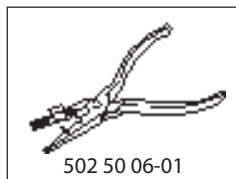

NOTE!
It is important that the tip of the contact coil hits the centre of the ignition lead in order to prevent sparks which in turn cause disruptions in the ignition.

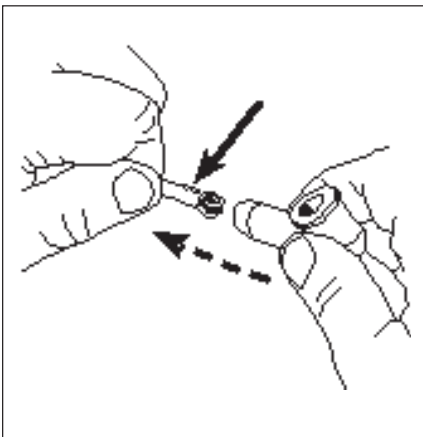

Attach the ignition coil to the ignition cable.

Attach the ignition coil to the ignition cable and ensure that the wire is folded along the cable.
Slide the contact coil into the spark plug cover.

TIP!
Lubricate the hole in the spark plug cover so that it is easier to slide in the contact coil.

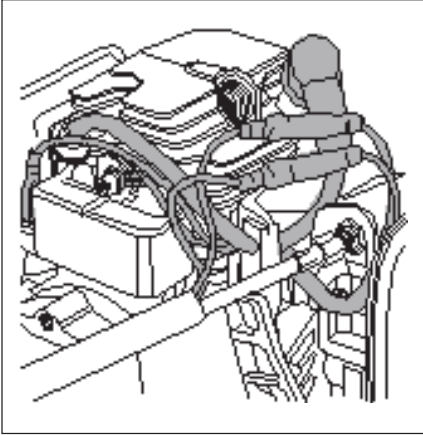

Still no spark?
Check other cables and connections.

Still no spark?
Check other cables and connections for poor contacts (dirt, corrosion, cable breakage and damaged insulation).

See chapter 3 "Throttle".

TIP!

Use an Ohmmeter in order to easily check if cable breakage has occurred, due to pinching, for example.

If the spark plug still does not fire, the ignition system should be replaced.



Dismantling

Dismantle the air filter cover, spark plug, cylinder cover and the cover over the lever arm of the carburettor.

Unhook the throttle cable from the carburettor.

Dismantling

The following components must be dismantled for the ignition system to be accessible:

The air filter cover, spark plug and cylinder cover.

Pry off the plastic cover over the lever arm on the carburettor.

Unhook the throttle cable from the carburettor.

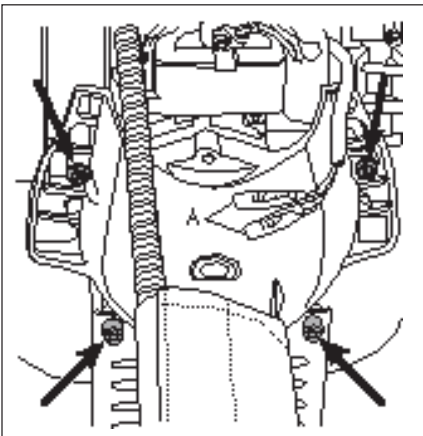

Disconnect the short-circuit cables (A).
Separate the engine body from the fan housing cover.

Disconnect the short-circuit cables (A).
Remove the 4 screws (A) and lift off the engine body.

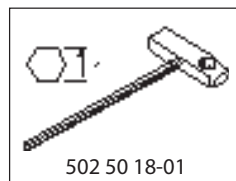

Dismantle the ignition module.

Dismantle the ignition module.
Disconnect the short-circuit cable (B) from the ignition module.
Pull out the cable shoe (C).
Remove the screws (D) and remove the ignition module.

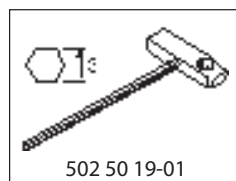
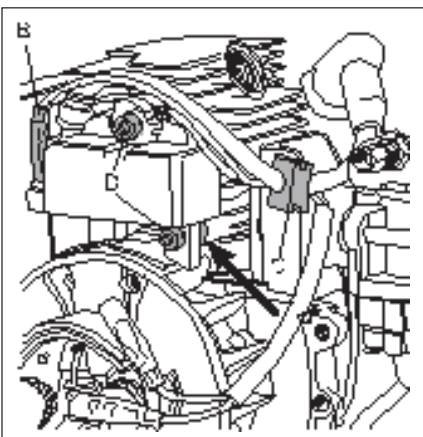

NOTE!
Do not loose the insulation sleeves that are placed between the ignition module and the cylinder.

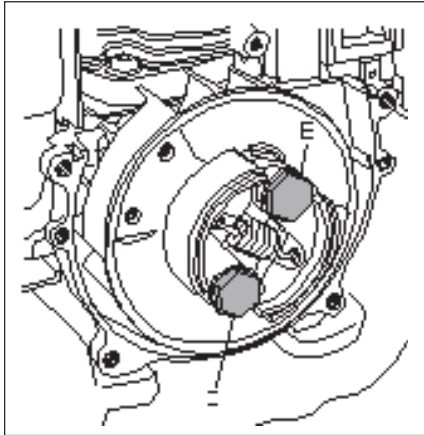

Dismantle the centrifugal clutch.

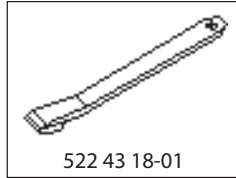

522 43 18-01

Position the piston stop 522 43 18-01 in the spark plug hole so that it is on top of the piston top in the combustion room.

Remove both screws (E) that hold the centrifugal clutch.

Lift off the clutch.

Note the spacers between the flywheel and the centrifugal clutch.

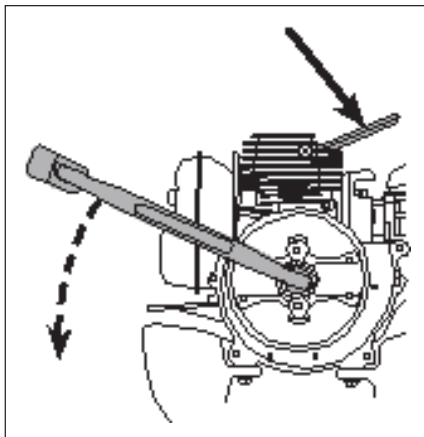

Remove the nut holding the flywheel.

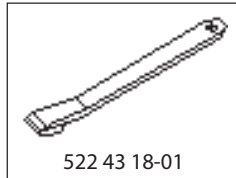

522 43 18-01

Remove the nut holding the flywheel.

Loosen and remove the flywheel nut.

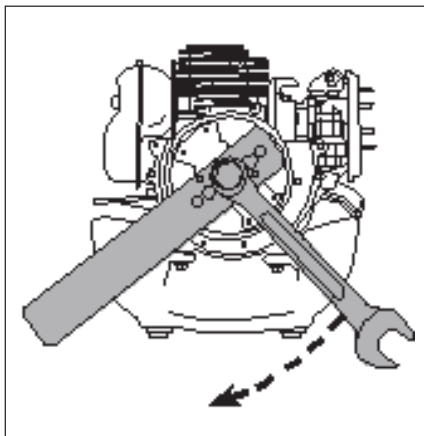

Remove the flywheel.

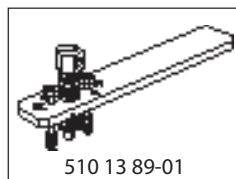

510 13 89-01

Dismantle the flywheel from the crankcase using the puller no. 510 13 89-01.

Gently knock the puller screw with a hammer, if the flywheel sits tightly on the crankshaft.

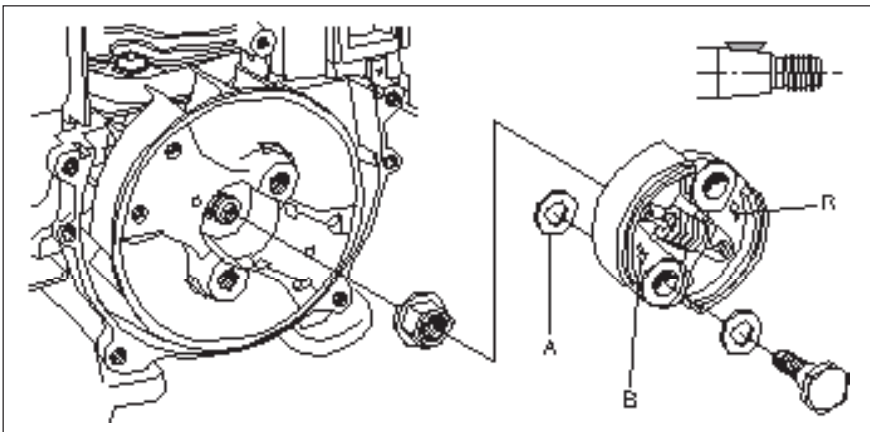

Assembly

Check that the key way in the flywheel and the key way in the crankshaft are undamaged, as well as the key.

Fit the flywheel and centrifugal clutch. Do not forget the flat spacers (A).

NOTE!

Turn the clutch so that the arrows (B) that indicate the direction of rotation are visible from the outside.

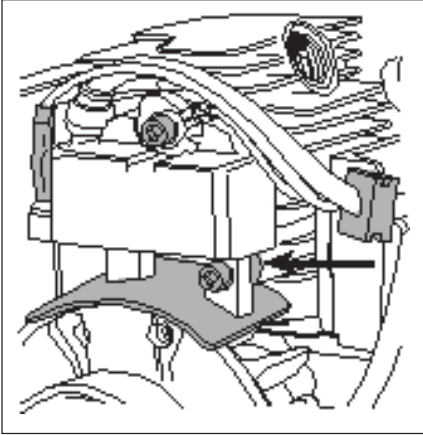

Assemble the ignition module.
Adjust the air gap.

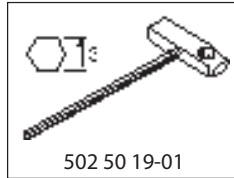

Fit the ignition module on the cylinder.

NOTE!

Do not forget the spacer sleeves between the cylinder and the ignition module.

Adjust the air gap between the ignition module and the permanent magnets on the flywheel to 0.3 mm and tighten the screws.

Assemble other parts in the reverse order as set out for dismantling.

Fuel system

3

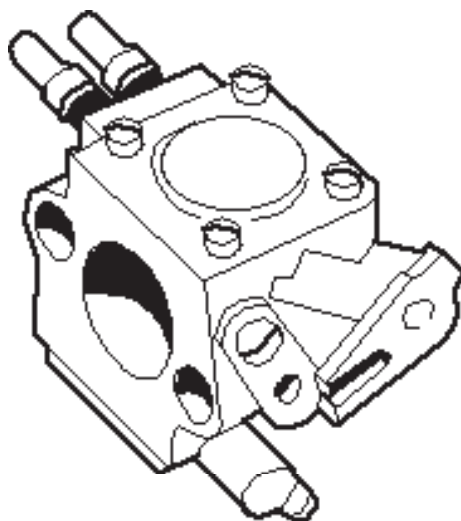

Contents

Air filter	14
Tank venting	15
Fuel filter	15
Carburettor	16
Assembly	20
Carburettor settings	20
Throttle handle	21
Trouble Shooting Guide	23

In addition to the fuel tank and carburettor, the fuel system consists of the air filter, fuel filter and tank venting.

All these components interact so that the engine receives the optimal mixture of fuel and air to make it as efficient as possible. Very small deviations in the carburettor setting or a blocked air filter have a large effect on the running and efficiency of the engine.

The carburettor can come from several different manufacturers on our models, but the function and repair methods are essentially the same.

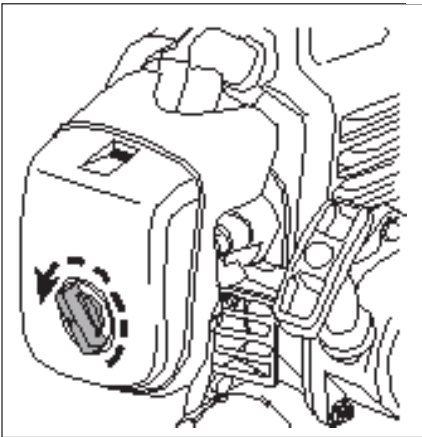

Air filter

Dismantle the air filter cowling. Remove the air filter and clean it in warm soapy water.

A damaged filter should be replaced with a new filter.

Air filter

Dismantle the air filter cover by turning the knob. Lift off the air filter.

The filter is manufactured of foamed plastic and should be cleaned in tepid soapy water.

A damaged filter should be replaced with a new filter.



WARNING!

Do not clean not the filter with petrol. Hazardous!

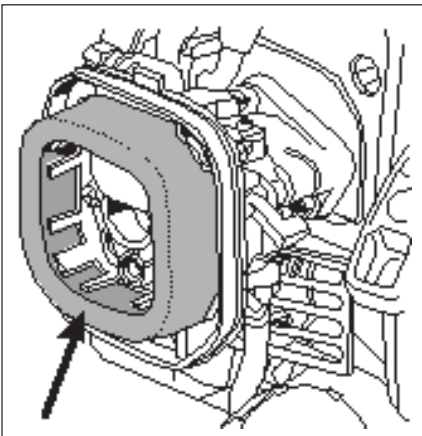

NOTE!

Make sure that the air filter is free of cleaning agent before it is impregnated with air filter oil.



505 69 85-70

Impregnate the filter with air filter oil.

TIP!

Use Husqvarna's cleaning agent Active Cleaning no. 505 69 85-70.

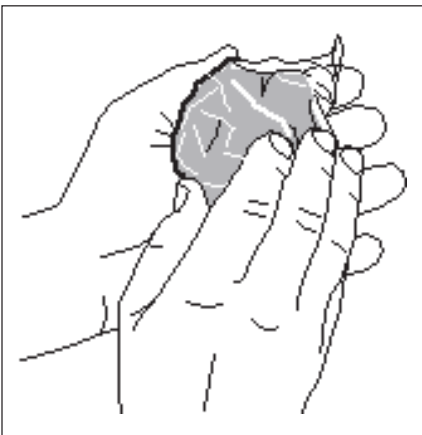

531 00 60-76

Impregnate the filter with air filter oil.

TIP!

Place the filter in a plastic bag and pour about a tablespoon of air filter oil no. 531 00 60-76 into the bag.

Massage the oil into the air filter.

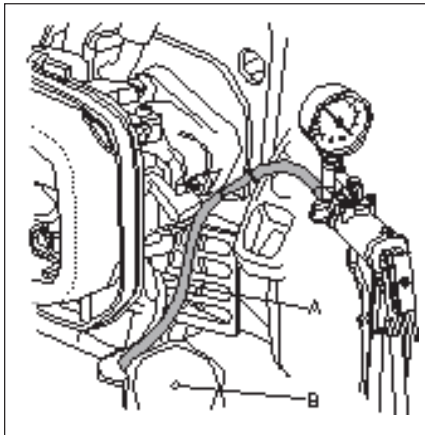

Tank venting

Check that the tank venting valve works correctly.



531 03 06-23

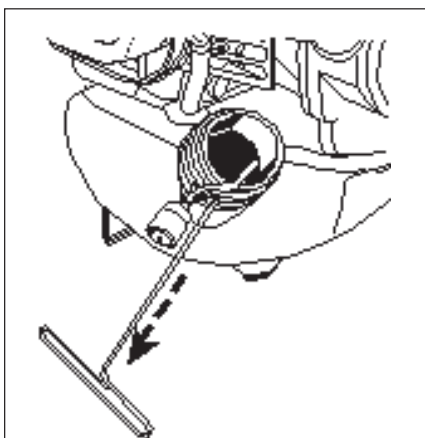
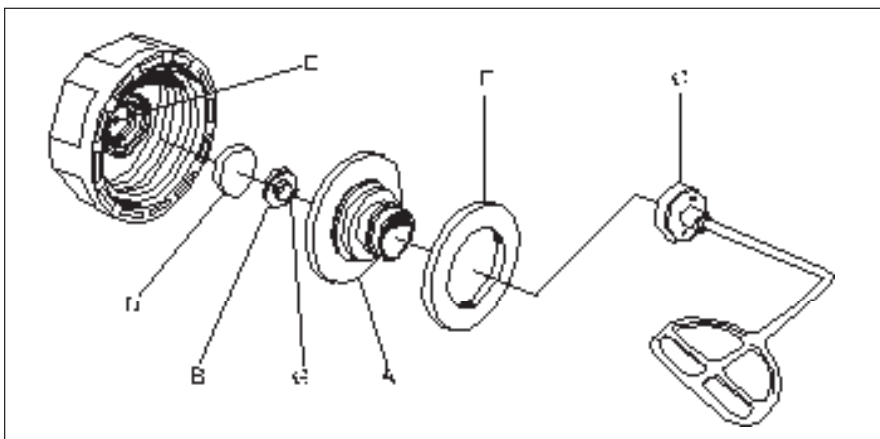

Fuel filter

The fuel filter can be removed through the tank's fill hole.

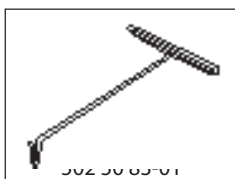

502 50 83-01

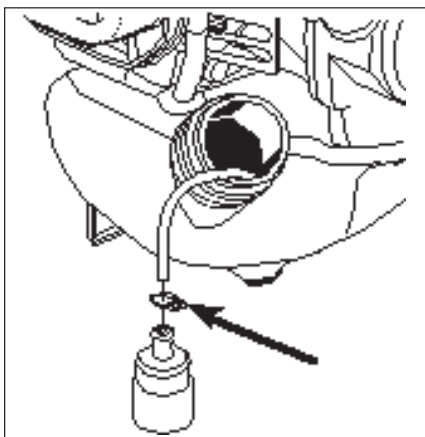

Clean the filter externally if it is not too dirty.

Replace the filter if required.

Tank venting

Tank venting takes place through the fuel cap and needs to be functional for the engine to work.

- Empty the fuel tank.
- Remove the air filter cover.
- Remove the transparent fuel hose (A) (return hose) from the carburettor.
- Connect the fuel hose to pressure tester no. 531 03 06-23.
- Make sure the hose bushings in the tank are leak tight.
- Cover the hole in the fuel cap (B) with your thumb.
- Pump up a vacuum of 50 kPa (0.5 bar) in the tank.
- Remove your thumb from the hole in the fuel cap.

The pressure should revert to atmospheric pressure within 15 seconds.

The fuel cap can be taken apart for cleaning.

Use a screwdriver and prise off the housing (A) that contains the non-return valve (B) and cover (C).

Blow the filter (D) and the hole in the fuel cap (E) clean with compressed air. Assemble the fuel cap in reverse order to that in which it was dismantled.

Make sure the seal (F) is not damaged.

NOTE!

There is a small slit (G) in the non-return valve (B) that only becomes visible when you carefully squeeze its sides. If the valve is undamaged, the slit is not visible in its normal position.

Replace the non-return valve if necessary.

Fuel filter

The fuel hose in the tank contains a fuel filter. It is accessible through the fill hole. Pull out the filter using tool 502 50 83-01.

If the filter is not too dirty, its surface can be cleaned with a brush.

Otherwise it must be replaced.

Check the fuel hose for cracks and leaks.

Make sure that the filter's connection neck is inserted as far as possible into the fuel hose and that the O-ring is sufficiently tight so that the filter cannot slide off the tube.

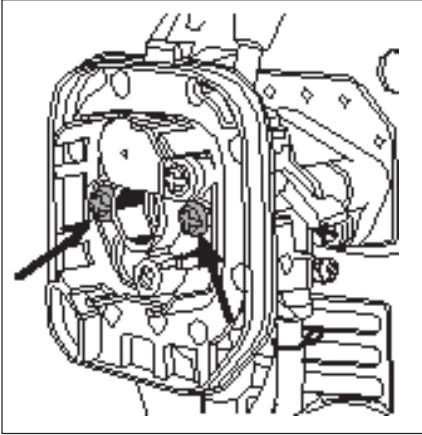

Carburettor

Dismantling

Remove the carburettor cover and the air filter then blow clean around the carburettor

Dismantle the throttle cable and fuel hoses.

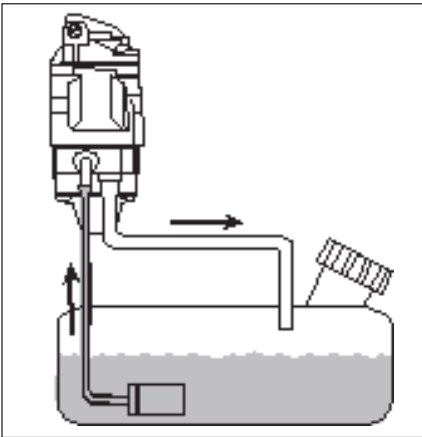

With the help of the fuel pump's bellows press fuel through the carburettor and fill all ducts with fuel.

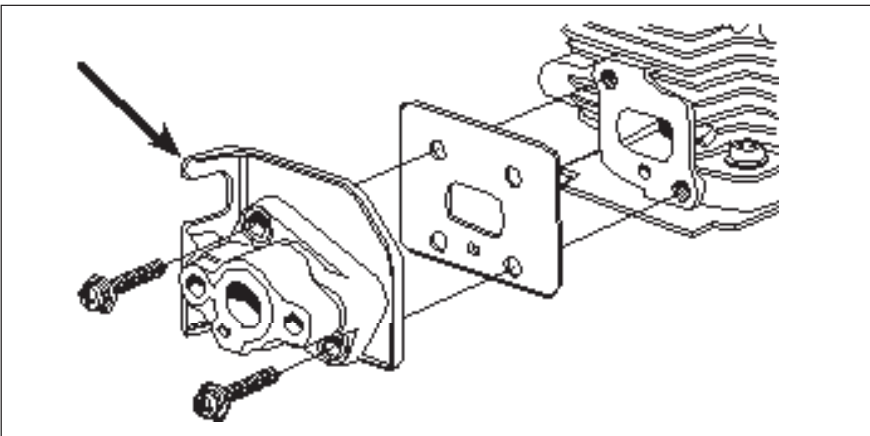

Inspect the distance piece for crack formation or other damage that may result in leakage, which in turn can cause uneven idling and starting difficulties.

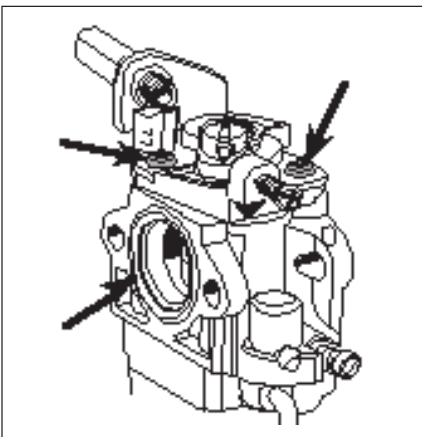

Dismantling the carburettor

Dismantle the valve mechanism.

If the valve or its bearing are damaged the entire mechanism should be replaced.

Carburettor

Dismantling

1. Remove the carburettor cover and the air filter.
2. Close the choke valve and blow off any dirt around the carburettor.
3. Disconnect the throttle cable.
4. Dismantle the fuel hoses from the carburettor and note how they are connected so that the fuel pump works as intended.
5. Open the choke valve and remove the carburettor screws. Lift off the air filter holder.

With the help of the fuel pump's bellows press fuel through the carburettor and fill all ducts with fuel.

Any vapour bubbles that block the ducts are pushed out.

In doing so helps to start the engine.

Dismantling the carburettor

Remove the two screws and lift off the entire throttle mechanism.

The valve stop screw (B) may need to be unscrewed a few turns.

Note the sealing ring on the connection flange so that it does not get lost or damaged.

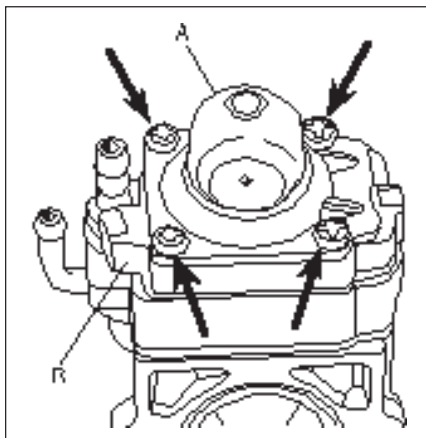

Dismantle the control diaphragm.

Remove the 4 screws.

These are long and hold together the complete carburettor.

Now lift off the fuel pump's bellows (A), valve housing (B) and control diaphragm.

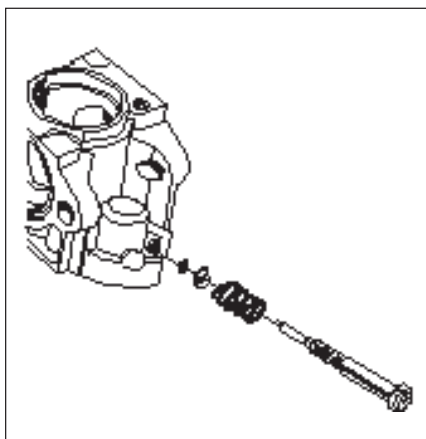

Dismantle the high-speed screw.

Dismantle the high-speed screw.

Before dismantling, note how many turns it is open.

The basic setting is 1.5 turns open.

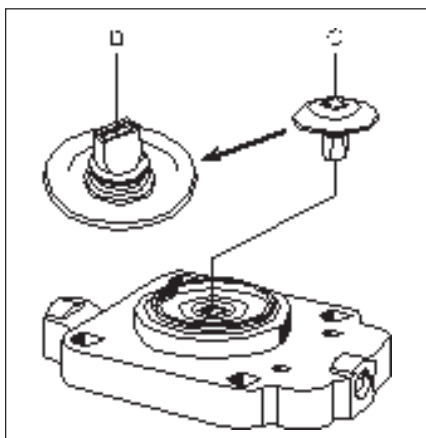

Lift up the non-return valve (C) and check that the seals are intact.

Carefully lift up non-return valve (C) using your nails.

Clean the valve housing.

Clean the valve housing and check that the channels are open.

Check that the non return valve's seals (D) are undamaged by carefully squeezing the short sides together.

Replace the valve if necessary.

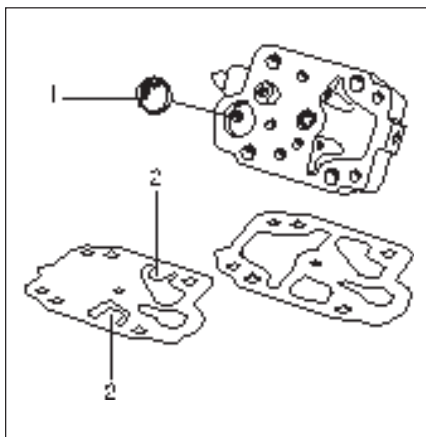

Remove the pump diaphragm to check for wear and damage.

Carefully remove the pump diaphragm and its gasket.

Clean or replace the fuel screen (1).

Check the diaphragm for wear to the valve flaps (2). Hold it, for example, up to the light to discover holes in the material.

Clean the fuel screen (1). Remove it for replacement if necessary using a needle.

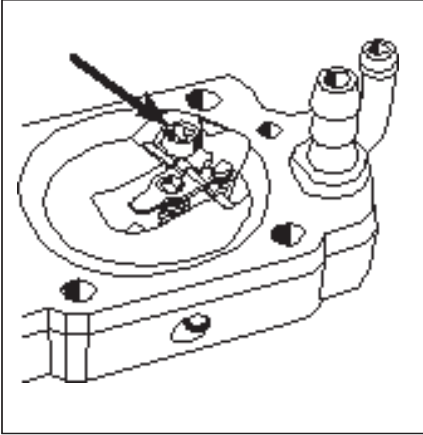

Dismantle the lever arm and needle valve to check for wear and replacement if necessary.

Loosen the screw and lift off the lever, axle, needle valve and spring. Exercise care so that the spring does not fly out.

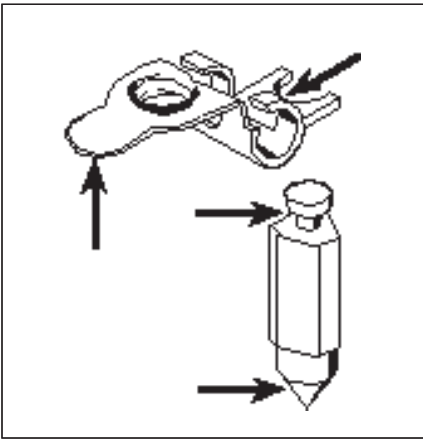

Check the lever arm and needle valve for wear.
Replace damaged parts with new parts.

Check the wear to the lever arm partly by the contact points against the control diaphragm and partly by the cut-outs for the needle valve.

Also check wear to the tip of the needle valve and the groove for the lever arm. Replace damaged parts with new parts.

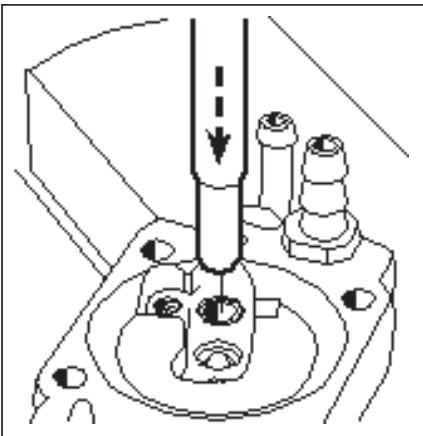

Replace the needle valve's seat.

Press out the needle valve's seat for replacement. Use a suitable punch \varnothing 4.5 mm.

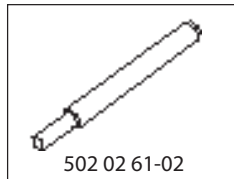

NOTE!

Replace the seat, needle valve and lever arm at the same time.

The needle valve's seat should be pressed in level with the carburettor housing. Use a vice with soft jaw guards to avoid damage to the needle valve's seat.

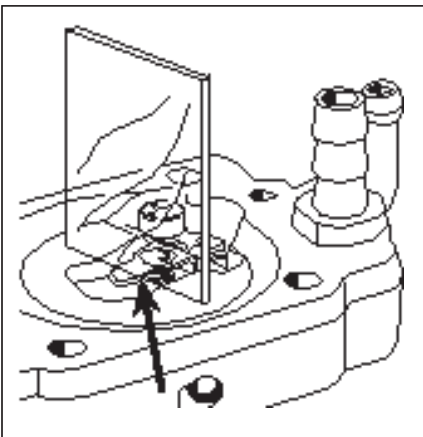

Check the position of the lever arm.

Assemble the parts in the reverse order as set out for dismantling.

Check that the lever arm lies flush with the diaphragm housing.

Too high setting = too much fuel.

Too low setting = too little fuel.

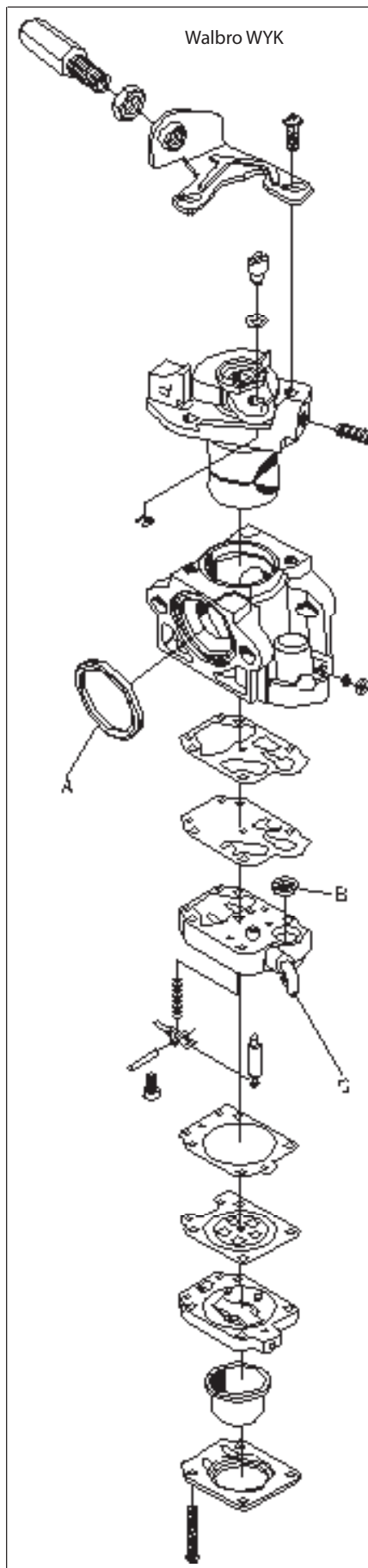

Assembling the carburettor

Clean and inspect all parts.

Worn or damaged parts are replaced with new ones.

Pay attention to the following when the carburettor is assembled in the reverse order to dismantling:

1. Make sure the sealing ring (A) has its wide edge against the carburettor housing.
2. The screen (B) must be clean and undamaged.

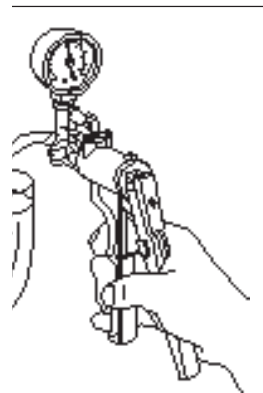

Assembling the carburettor

Clean and inspect all parts.

Worn or damaged parts are replaced with new ones.

Pay attention to the following when the carburettor is assembled in the reverse order to dismantling:

1. Make sure the sealing ring (A) has its wide edge against the carburettor housing.
2. The screen (B) must be clean and undamaged.

Check that the carburettor is sealed.

Connect the pressure tester no.

531 03 06-23 to the fuel inlet (C) on the carburettor.

Pump up the pressure to 50 kPa.

Lower the carburettor in a vessel with petrol in order to discover any leaks more easily.

No leakage is permitted.

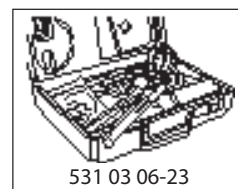

531 03 06-23

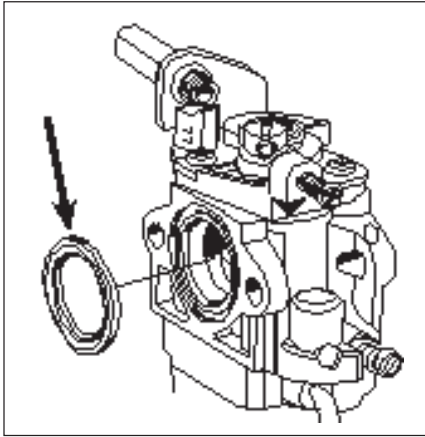

Assembly

Check that the sealing ring is seated correctly.

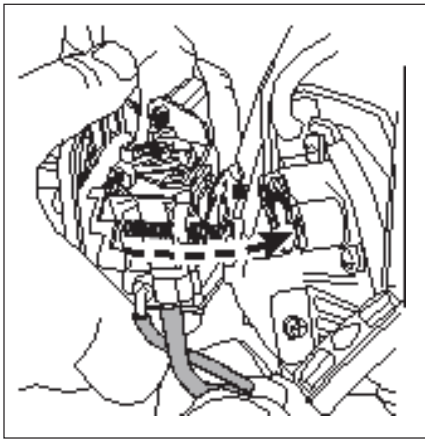

Connect the fuel hoses and fit the air filter holder and carburettor to the distance piece.

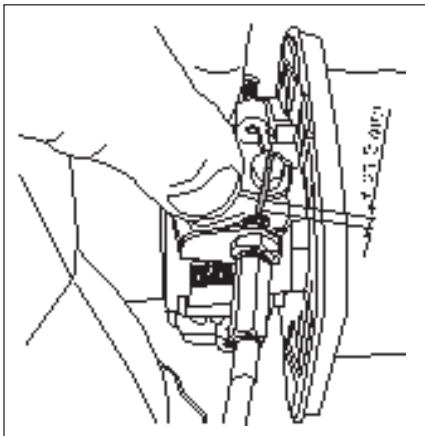

NOTE!

Adjust the throttle cable at the connection with the carburettor so that the lever arm on the cable connection can be moved a further few millimetres at full throttle using the throttle.

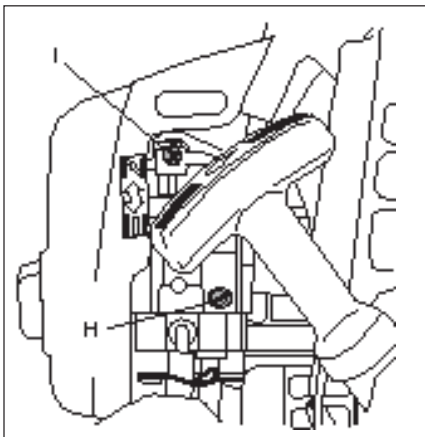

502 71 14-01

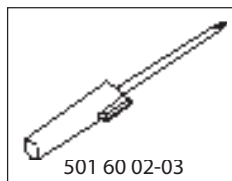

501 60 02-03

Assembly

Check that the sealing ring is seated correctly on the carburettor before this is fitted on the engine.

The wide edge on the ring should be nearest to the carburettor housing.

Connect the fuel hoses and ensure that they sit correctly.

Hold the air filter in position and insert the carburettor screws through the air filter holder and carburettor body. Place the carburettor gasket in position and screw the carburettor tight to the distance piece.

NOTE!

Adjust the throttle cable at the connection with the carburettor so that the lever arm on the cable connection can be moved a further few millimetres at full throttle using the throttle.

Carburettor settings

The carburettor's job is to deliver a combustible mixture of air and gasoline to the cylinder.

The amount of this mixture is controlled with the throttle.

The composition of the mixture is controlled by an adjustable high speed jet (H). If the screw is turned anticlockwise, the fuel/air mixture becomes "richer" (more fuel). A rich mixture gives a lower speed.

Setting the high speed jet:

1. Screw the high speed jet (H) into the bottom of its seat.
2. Then screw out the needle 1.5 turn (basic setting).
3. Run the engine warm for about 4 minutes at 9,500–10,000 r/min.
4. If the idle speed exceeds 3,700 r/min it can be lowered with the idle screw (T).
5. Then turn the H-needle anticlockwise so that the speed drops by 300 r/min.
6. Then adjust the idle speed to 2,800 – 3,100 r/min by turning the T screw.

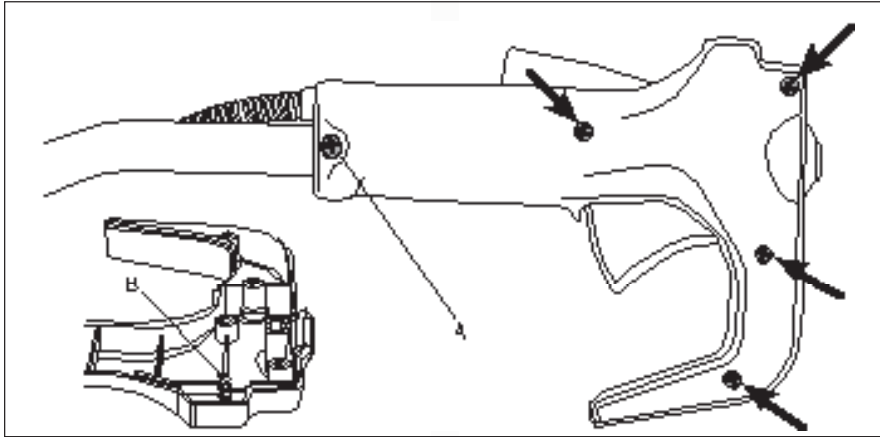

Throttle handle

Dismantling

If the throttle is to be removed from the handle, only screw (A) needs to be removed.

If the two halves of the throttle are to be separated, all screws must be removed.

NOTE!

When lifting off the handle half, be careful that the spring (B) does not get lost.

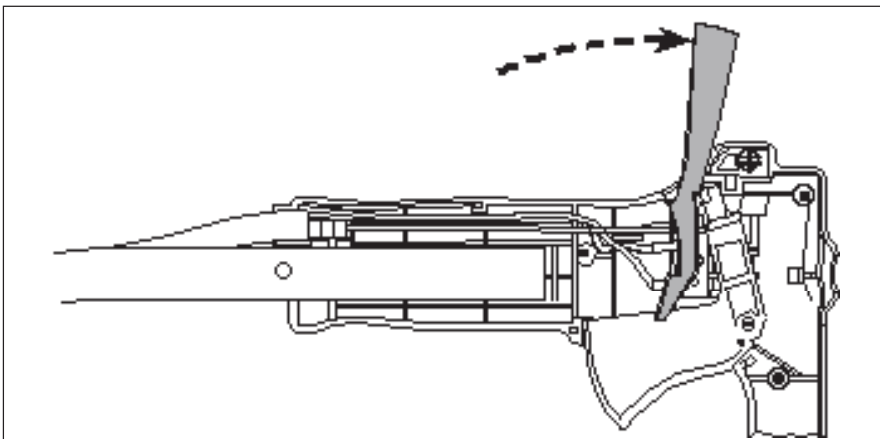

Using a screwdriver, carefully lift up the lock preventing accidental throttle operation, and slow down rotation until the spring tension ceases.

Lift off the lock.

Note the location of the return spring.

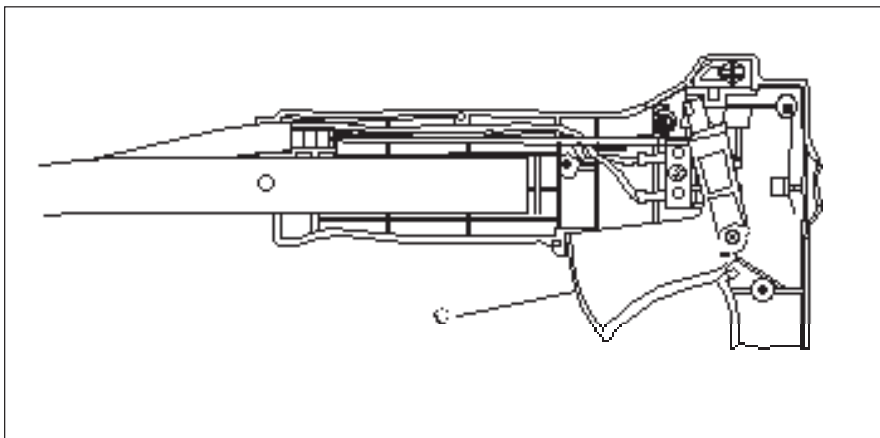

Lift up the throttle control (C) and note how the return spring is fitted.

Unhook the throttle cable if it needs replacing.

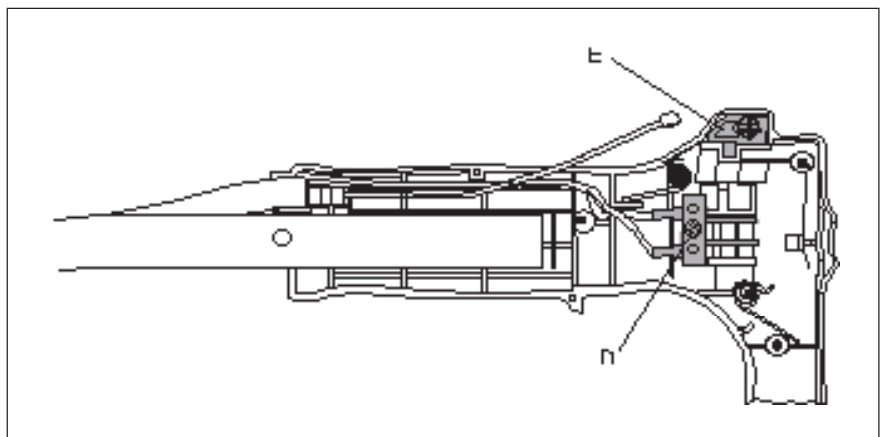

Remove the screw (D) and lift off the two contact strips of the stop switch and the control button (E).

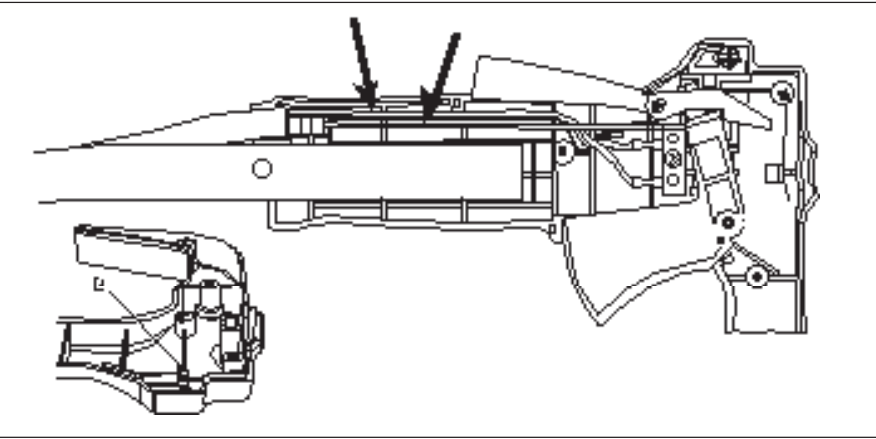
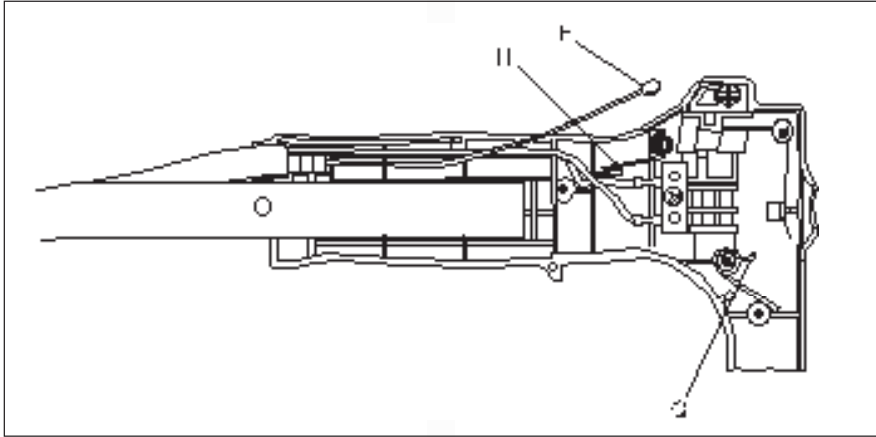

Assembly

1. Hook the throttle cable (F) into the throttle control.
2. Insert the return spring (G) in the hole in the throttle control.
3. Position the throttle control with spring over the bearing pin and tension the spring.
Press the throttle control down.
4. Seat the return spring (H) in position.
5. Position the lock preventing accidental throttle operation over the bearing pin and tension the spring until the lock can be slid down to engage and hold the throttle control.
6. Check that the throttle cable and short-circuit cables are properly seated and will not get pinched.
7. Check that the spring (B) is in position in the right-hand handle half.
Place the latter in its correct position and tighten all the screws.

Trouble Shooting Guide

Symptom		Starting			Low speed			Acceleration/ Deceleration			High speed	
		ifficult to start	Flooding, fuel leakage	Difficult to prime when starting	Engine does not idle	Idles too slowly	Idling does not stabilise	Stops when idling	Engine does not accelerate	Engine stops when decelerating	Poor acceleration capacity	Poor performance at high speed
Probable causes												
Stop screw for the throttle not working		☒			☒		☒	☒				
Fuel tank/hose	Fuel filter blocked	☒		☒	☒		☒	☒	☒			☒
	The fuel hose blocked	☒		☒	☒		☒	☒	☒			☒
	Air in fuel ducts	☒		☒	☒		☒	☒	☒			☒
	Incorrect/poor fuel	☒					☒					☒
Pump diaphragm	Vacuum pulse leakage								☒			☒
	Vacuum pulse duct blocked								☒			☒
	Loose screw(s) on the pump cover		☒						☒			☒
	Faulty pump diaphragm								☒	☒		☒
Flow bellows	Flow bellows damaged			☒								
	The needle valve faulty	☒		☒			☒	☒	☒			☒
Carburettor is not fitted correctly					☒		☒		☒			☒
Faulty heat insulation seal				☒		☒		☒			☒	
Needle valve's lever	Lever arm damaged	☒	☒			☒			☒			☒
	Lever arm too high		☒			☒		☒		☒		
	Lever arm too low								☒			
	Lever arm does not work correctly	☒	☒	☒	☒	☒	☒	☒	☒	☒		☒
Needle valve's spring	The spring is deformed		☒					☒				☒
	The spring is not fitted correctly						☒	☒	☒			☒
Control diaphragm	Diaphragm is damaged	☒	☒	☒			☒		☒			☒
	Faulty seal	☒	☒	☒								☒
Needle valve	Valve jams	☒		☒					☒			
	Valve worn	☒	☒			☒	☒	☒		☒		☒
	Foreign object in the valve guide	☒	☒			☒	☒	☒		☒		☒

Centrifugal clutch

4

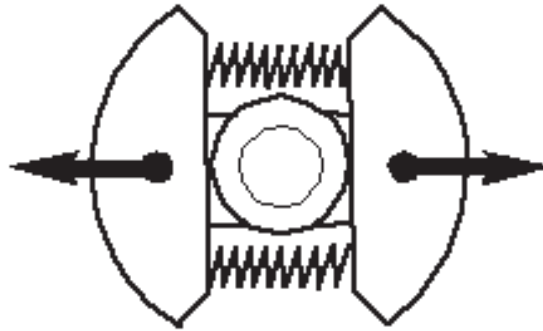

Contents	
Centrifugal clutch, dismantling	26
Centrifugal clutch, assembling	27
Clutch drum, drive axle and AV element	27

The centrifugal clutch has the task of transferring the power from the engine to the cutting equipment's drive axle. As the name implies, it works according to a centrifugal principle.

This means the clutch's friction shoes are thrown outwards towards the clutch drum at a certain engine speed. When the friction against the drum is sufficiently great it drives the drive shaft at the same speed as the engine.

Some slipping occurs between the clutch and the clutch drum when accelerating as well as in the reversed situation when the cutting equipment jams. Thereby preventing abnormal load changes on the crankshaft.

The engagement speed has been carefully tested so that the engine can idle without the cutting equipment's drive shaft rotating.

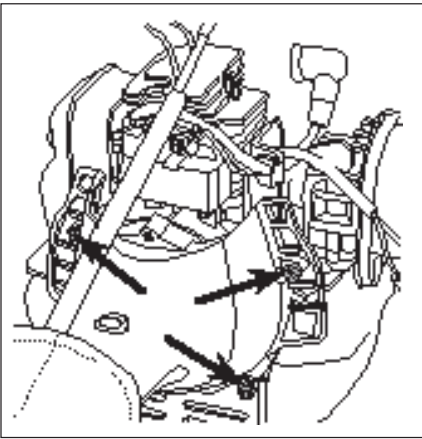

Centrifugal clutch

Dismantling

Dismantle the cylinder cover and the air filter cover.

Separate the short-circuit cables and disconnect the throttle cable.

Remove the screws holding the clutch cover and lift off the assembly.

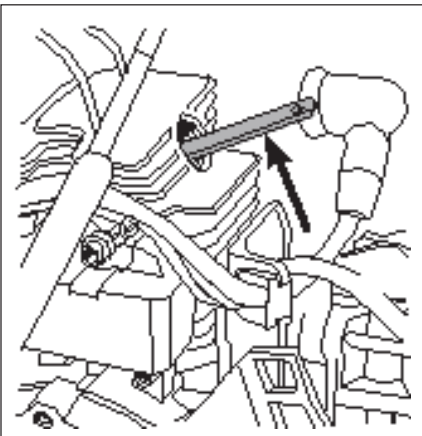

Place the piston stop in the spark plug hole.

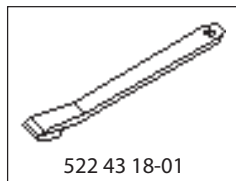

522 43 18-01

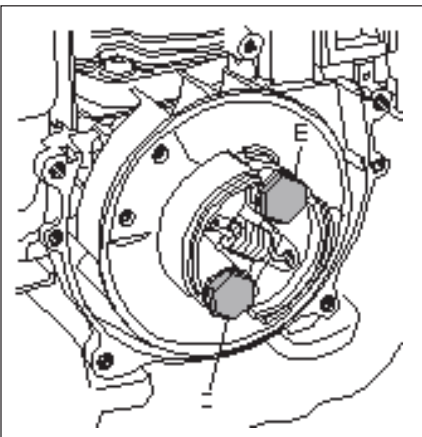

Dismantle the centrifugal clutch.

Centrifugal clutch

Dismantling

1. Remove the cover over the air filter.
2. Separate the short-circuit cables.
3. Disconnect the throttle cable from the carburettor.
4. Dismantle the spark plug and the cylinder cover.
5. Remove the 4 screws holding the clutch cover against the fan housing cover.
6. Lift off the entire assembly.

Stop the piston from moving by inserting piston stop 522 43 18-01 in the spark plug hole.

Remove the two screws (E) holding the centrifugal clutch.

Lift off the clutch.

Note the spacers between the flywheel and the centrifugal clutch.

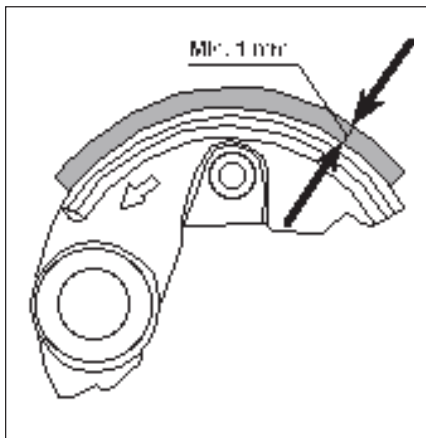

Twist apart the clutch.
Inspect and replace damaged or worn parts.

Twist apart the clutch and inspect the spring and lining with regard to wear and damage.

The thickness of the lining must be at least 1.0 mm at the most worn point.

NOTE!

Both clutch shoes should be replaced even if only one of them is showing signs of heavy wear. This is to avoid engine vibration caused by imbalance in the clutch.

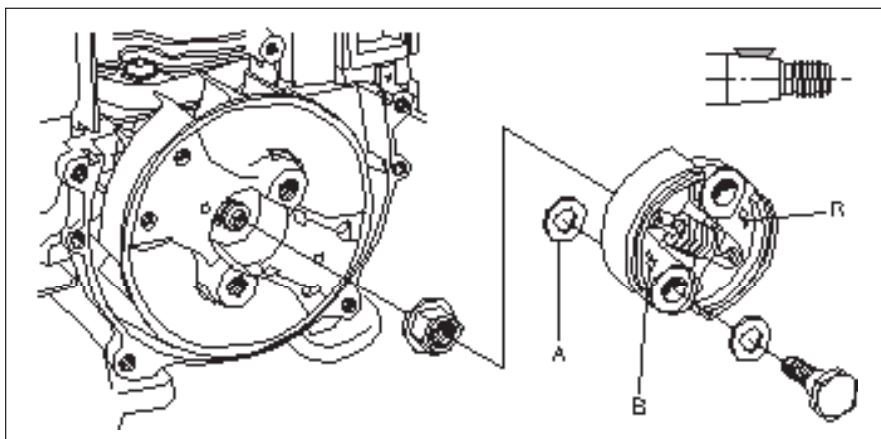

Assembly

Check that the key way in the flywheel and the key way in the crankshaft are undamaged, as well as the key.

Fit the flywheel and centrifugal clutch. Do not forget the flat spacers (A).

NOTE!

Turn the clutch so that the arrows (B) that indicate the direction of rotation are visible from the outside.

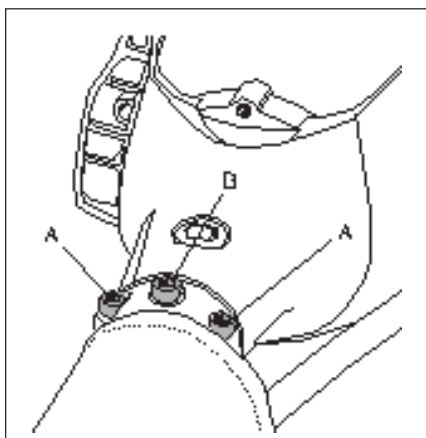

Clutch drum, drive axle and AV element

Dismantle the clutch cover from the shaft.
Pull the drive axle out of the shaft.

Clutch drum, drive axle and AV element

Loosen the screws (A).

Loosen the centre screw (B) to be able to pull the clutch cover off the shaft.

Pull out the drive axle from the shaft for inspection and possible change.

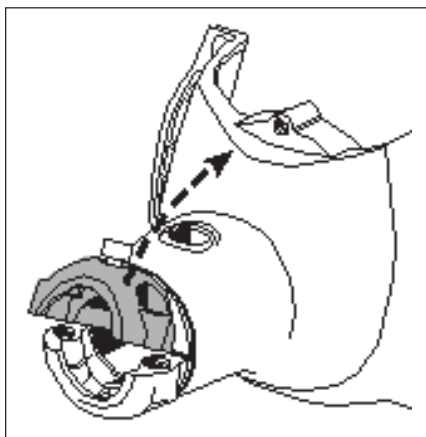
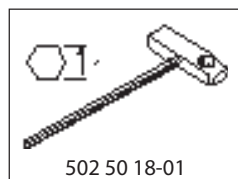

Dismantle the AV element.
Remove the two clamping halves from the shaft.

Dismantle the AV element.

1. Fold the upper clamping half upwards so that its guide pin comes off of the AV element.
2. Fold the lower clamping half downwards so that its guide pin comes off of the AV element.

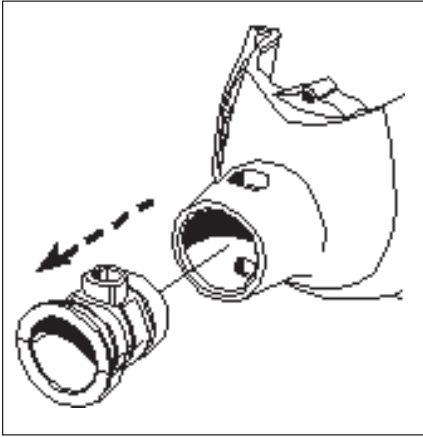

Dismantle the AV element.

Dismantle the AV element from the clutch housing.

Clamp the element with your fingers.

Use a blunt object, for example a mandrel. Insert the mandrels alternately in the holes in the clutch cover and push the AV element out.

If required, use soapy water or silicone spray to facilitate the dismantling.

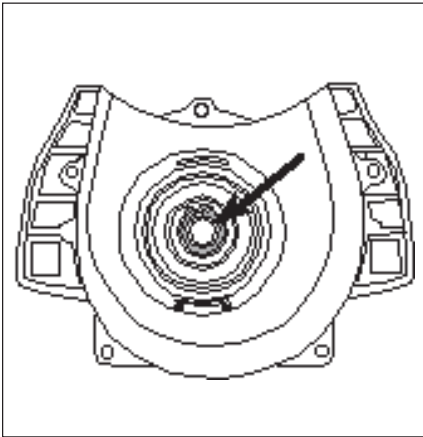

Dismantle the circlip holding the clutch drum.

Dismantle the circlip holding the clutch drum in place by using circlip pliers.

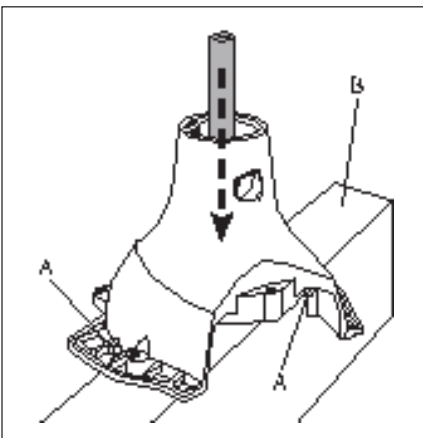

Push the clutch drum out of the cover.

Push out the clutch drum.

The pass between the ball bearing and the clutch drum shaft might be stiff. If that is the case then warm the entire cover up using a hot air gun.



WARNING!

Make sure the centre pins (A) are placed on each side of the counterhold (B). Otherwise there is a risk of the clutch cover being damaged.

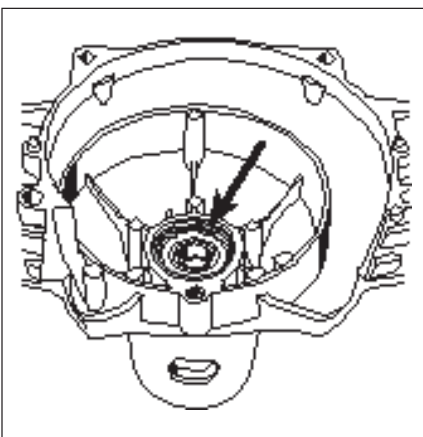

Dismantle the circlip and heat the clutch cover so the bearing can be dismantled.

Dismantle the circlip using circlip pliers.

Heat the clutch case to approx. 120°C using a hot air gun.

Knock the edge of the cover against a wooden block so the ball-bearing falls out or use a hammer and punch.

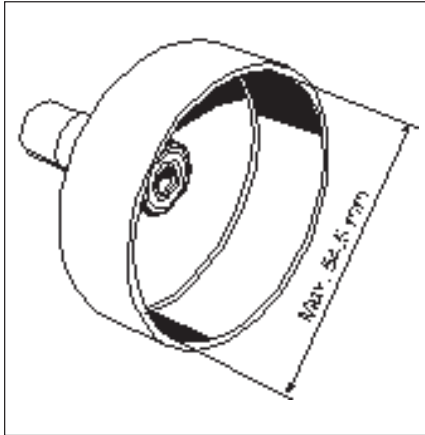

Check the inside diameter of the clutch drum. If it exceeds 54,5 mm it should be replaced.

Check the clutch drum for wear.

The diameter must not exceed 54,5 mm. If this is the case replace the clutch drum.

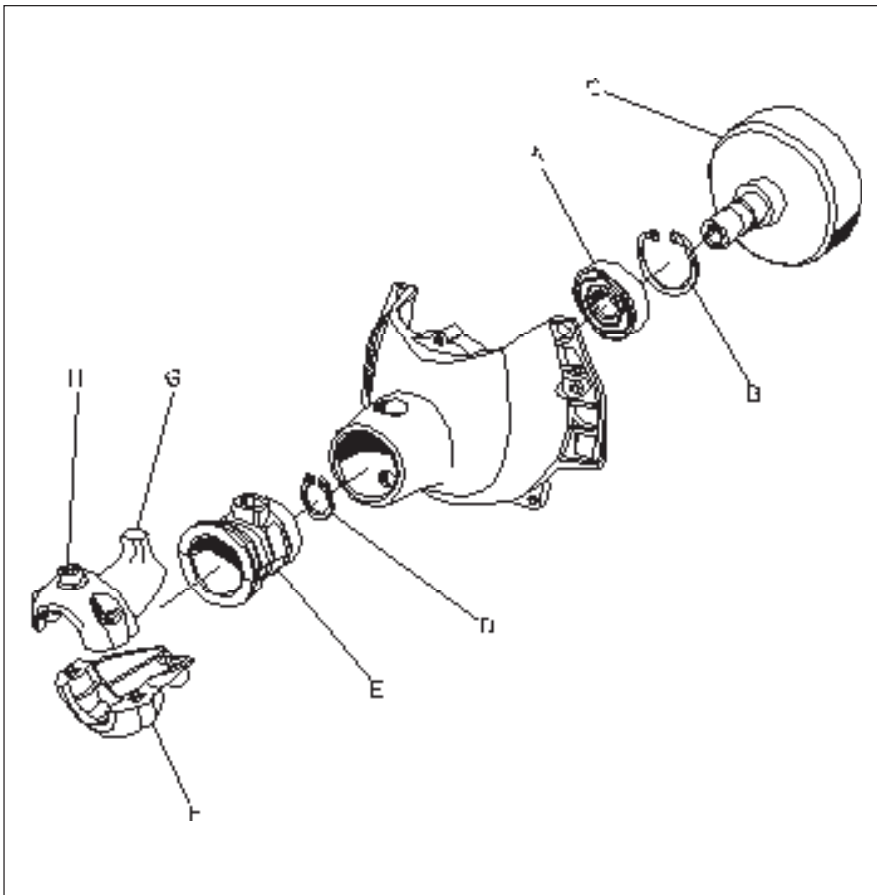

Assemble the different components in the reverse order as set out for dismantling.

1. Warm the clutch cover to about 120°C before assembling the ball bearing (A). Assemble the circlip (B) holding the ball bearing in place.
2. Push the clutch drum (C) in and assemble the circlip (D) holding it in place.
Rub the AV element (E) in with talc to facilitate the assembly and extend its service life.
3. Push the AV element into the clutch cover.
4. Push the lower bracket (F) into the AV element and then the upper bracket (G).
5. Assemble the complete clutch cover on the shaft and make sure the centre screw (H) can be screwed into the hole in the shaft.

Angle gear

5

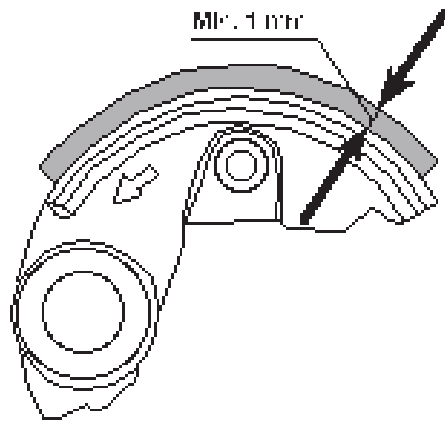

Contents	
Dismantling	32
Assembly	33

The angle gear has two purposes:

The first is to gear down the engine's high speed to better suit the lower speed a saw blade or trimmer requires to work efficiently.

Secondly, the angle gear contributes towards the operator's working stance so that it is comfortable and at the same time efficient. In other words, the power from the engine via the drive axle should be angled so that the cutting tool works parallel with the ground.

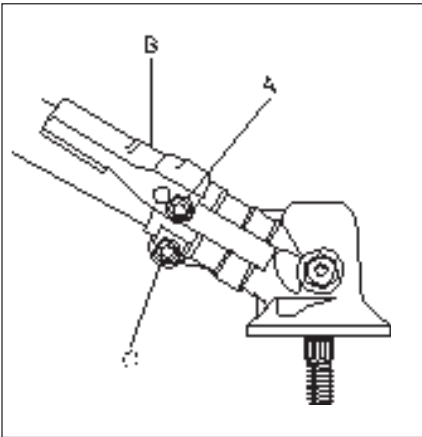

Dismantling

Remove the angle gear from the shaft.

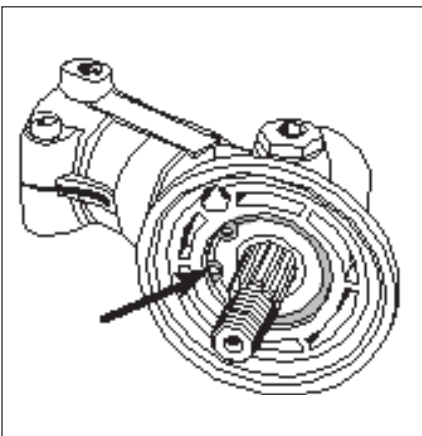
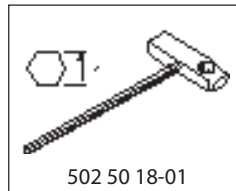

Remove the circlips holding the bearings on the input respective output shafts.

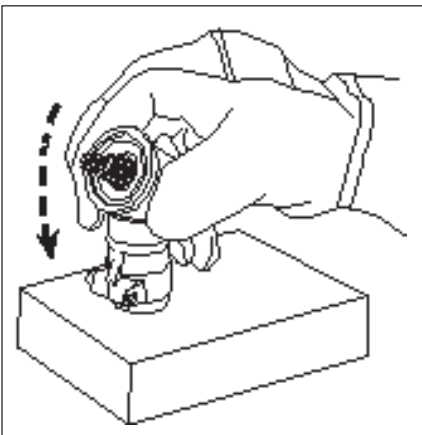

Heat the entire angle gear to approx. 140°C and first dismantle the input axle and then the output axle.

Dismantling

1. Remove the cutting equipment and guard.
2. Remove the screw (A) and lift off the plate (B).
3. Loosen the screw (C) holding the bevel gear against the shaft and remove the bevel gear.

4. Remove the support washers and the dust protection washer.
5. Use a pair of circlip pliers to remove the circlips holding the ball bearings by the output shaft (see picture) and the input shaft respectively.

Heat the entire angle gear using a hot air gun to approx. 140°C.

Knock the gear against a wooden block so that the input axle and the bearing fall out. Now lift out the output axle.

Wear protective gloves.

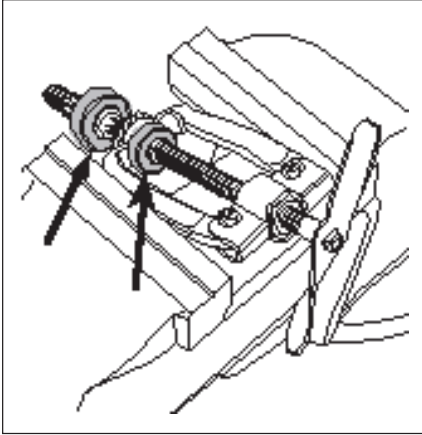

Dismantle the bearings from the output and input axles.

Dismantle the bearings from the output and input axles with the help of a small bearing puller.

TIP!

Hold the bearing puller in a vice so that it gains a better grip around the bearing.

Clean all components and inspect them for wear and damage. Replace damaged components.

NOTE!

Both cogwheels should be replaced at the same time, even if only one of them is damaged.

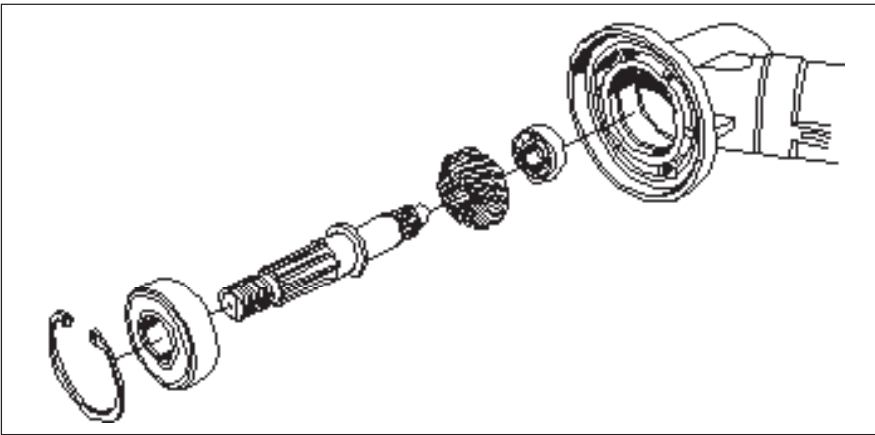

Assembly Output shaft

Start putting the bevel gear and the output shaft together.

1. Place the cogwheel on the shaft.
2. Push the two ball bearings in place.

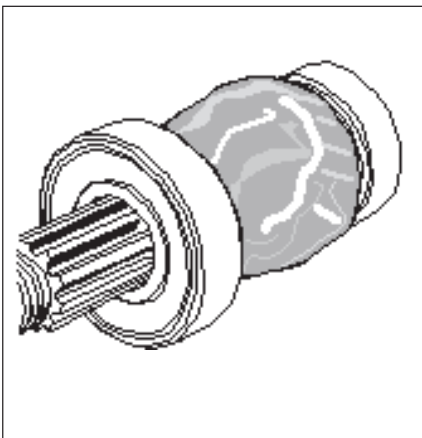

Grease the cogwheel thoroughly.



3. Grease the whole cogwheel with a large amount of gear housing grease 503 97 64-01 as per the picture.

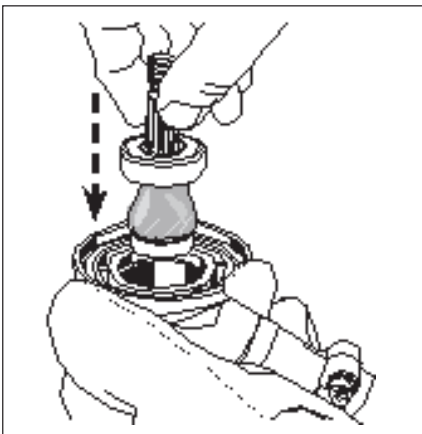

Warm the gear housing to about 140°C and push the output shaft into the gear housing.

4. Use a hot air gun to warm the gear housing to about 140 °C.

5. Push the output shaft into the gear housing.

Make sure the ball bearings touch bottom in their positions.

If required, use a suitable mandrel.

6. Fit the circlip.

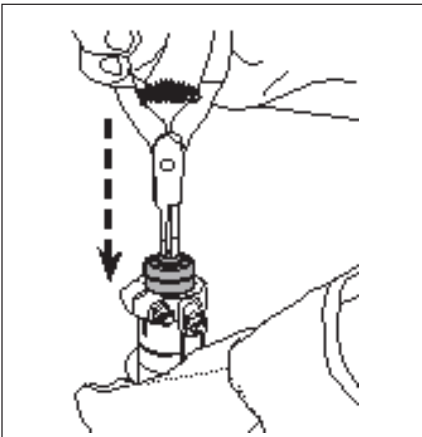
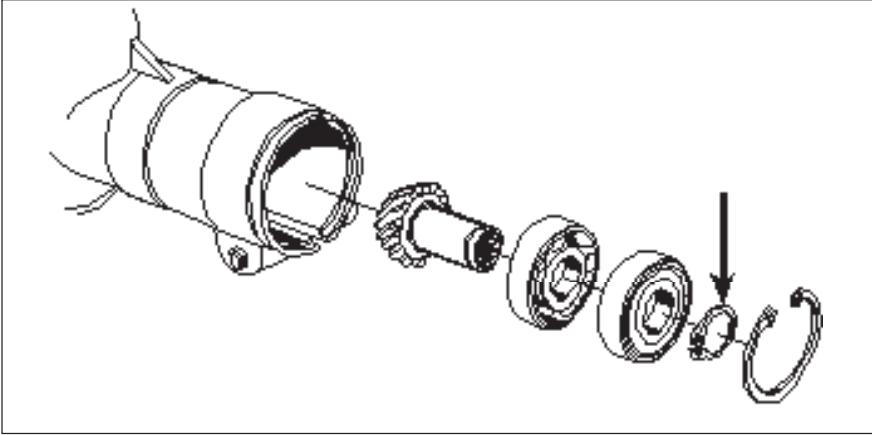

2. Warm the gear housing some more if needed.
3. Fit the input shaft.
4. Make sure the ball bearings touch bottom in their positions.

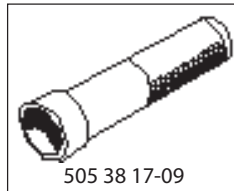

5. Fit the circlip for the ball bearings on the input shaft.
6. Assemble cutting attachment and spray guards in the reverse order as set out for dismantling.

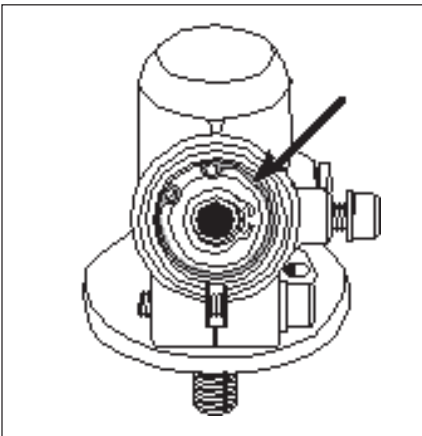

Input shaft

The input shaft should be fitted after the output shaft has been fitted.

1. Fit the ball bearings on the axle.

Place the outer ball bearing with the sealed side facing outwards.

Do not forget the circlip holding the ball bearings in place.

2. Make sure the gear housing is still hot enough (about 140°C) after the output shaft has been fitted.
3. Lift the input shaft in place using a suitable pair of pliers or a suitable sleeve.
4. Make sure the ball bearings touch bottom in their positions.

5. Fit the circlip for the ball bearings on the input shaft.
6. Assemble cutting attachment and spray guards in the reverse order as set out for dismantling.

Cylinder and piston

6

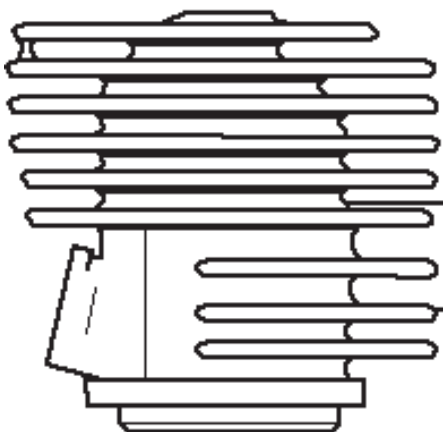

Contents	
Dismantling	38
Cleaning, inspection	39
Analysis and actions	39
Service tips	44
Wear tolerances	44
Assembly	45

The cylinder and the piston are two of the components exposed to most strain in the engine. They must withstand, for example, high speeds, large temperature swings and high pressure. Moreover, they must be resistant to wear. Despite these tough working conditions, major piston and cylinder failure is relatively uncommon. The reasons for this include new coatings in the cylinder bore, new types of oil and grease and refined manufacturing techniques.

When servicing these components, cleanliness is of the utmost importance. It is therefore recommended that the cylinder and the area around it be thoroughly cleaned before being dismantled from the crankcase.

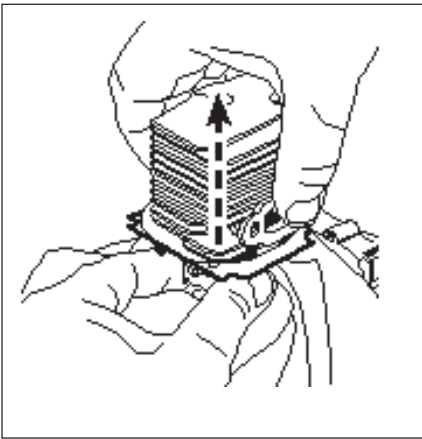

Dismantling

Dismantle the following components to make the cylinder accessible:

Cylinder cover, muffler with heat protective plate against the cylinder, spark plug and ignition module.

Dismantle the air filter, carburettor and distance piece.

Then loosen the 2 bolts holding the cylinder.

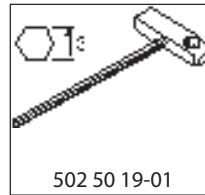
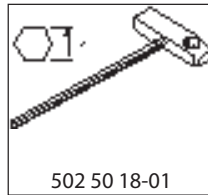

Carefully remove the cylinder straight up by rocking it backwards and forwards. Make sure that no dirt enters the crankcase.

Use a rag to cover the crankcase opening under the piston.

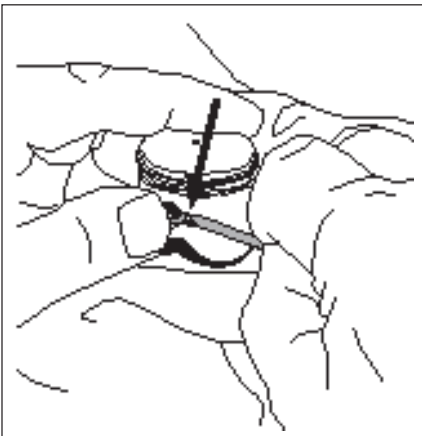

Remove the circlips from the gudgeon pin.

Use a pointed tool to remove the gudgeon pin circlips.

Keep your thumb over the circlip to prevent it from flying out.



Dismantle the piston.

Push the gudgeon pin from the piston using punch 505 38 17-05.

If the pin is too tight, dismantling is facilitated by carefully heating the piston using a hot air gun.

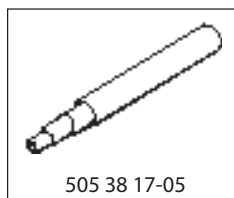

NOTE!

Do not lose the spacers that are on each side of the little-end.

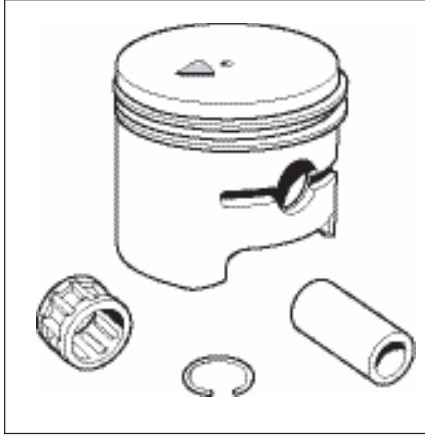

Cleaning, inspection

After dismantling, clean the individual components:

1. Scrape carbon deposits from the top of the piston.
2. Scrape carbon deposits from the cylinder's combustion chamber.
3. Scrape carbon deposits from the cylinder's exhaust port.

NOTE!

Scrape carefully with not too sharp a tool so as not to damage the soft aluminium parts.

4. Wash all the components.
 5. Inspect the different components for damage and wear.
- Check the piston and cylinder for seizure damage and wear.

Also see the "Analysis and actions" section.

Check the piston rings for wear and possible breakage.

Also see the "Analysis and actions" section.

Check the gudgeon pin.

- If it has blued, it must be replaced.
- If the piston moves too easily both the piston and the gudgeon pin must be replaced.

Check the needle bearing. If it is discoloured or damaged, it must be replaced.

Check the circlips. If they exhibit cracks or are discoloured (caused by overheating), they must be replaced.

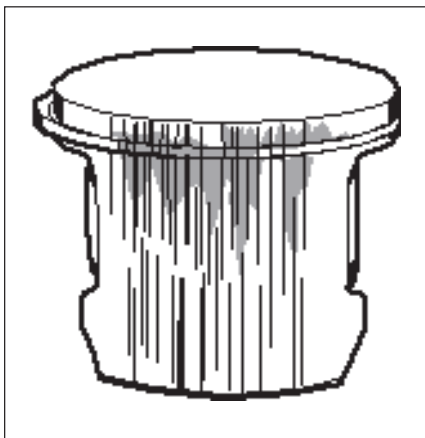

Small to medium size scores primarily in the middle of the exhaust port.

Analysis and actions

Experience tells us that piston or cylinder failure due to manufacturing errors are extremely rare.

The reason is usually due to other factors, which is evident from the following.

Note the reasons for the breakdown, repair the damage and take the actions required to prevent the same thing happening again.

Insufficient lubrication

The piston has small to medium size score marks usually in front of the exhaust port. In extreme cases heat development can be so great that material from the piston smears along the piston skirt and even in the cylinder bore.

Generally the piston ring is undamaged and moves freely in the ring groove

There can also be scores on the inlet side of the piston.

Cause:

- Incorrect carburettor setting. Recommended max. speed exceeded.
- Incorrect oil mixture in the fuel.
- Too low octane fuel.

Action:

- Check and change the carburettor setting.
- Change the fuel.
- Change to a higher octane petrol.

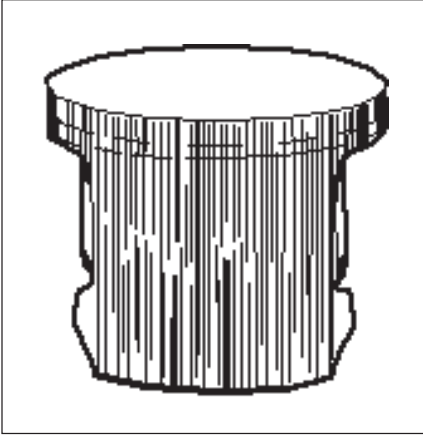

Medium to deep scores along the entire piston skirt on the exhaust side.

The piston ring starts to stick or is completely stuck in its groove and has therefore not been able to seal against the cylinder wall, which has resulted in further, intensive temperature increases in the piston

Seizure scores along the entire piston skirt on the inlet and exhaust sides.

Cause:

- Incorrect oil mixture in the fuel.
- Too low octane fuel.
- Air leaks.
 - Cracked fuel hose.
 - Leaking inlet gaskets.
 - Cracked distance piece or inlet manifold.
- Air leakage in engine body.
 - Leaking crankshaft seals.
 - Leaking cylinder and crankcase gaskets.
- Poor maintenance.
 - Dirty cooling fins on the cylinder.
 - Blocked air intake on the starter.
 - Blocked spark arrestor mesh in the muffler.

Action:

Change to a fuel with the correct oil mixture.
Change to a higher octane petrol.
Replace damaged parts.

Replace leaking gaskets and shaft seals.

Clean the cooling fins and air intake.

Clean or replace the spark arrestor mesh.

For the best results we recommend Husqvarna two-stroke oil or ready-mixed fuel that is specially developed for air-cooled two-stroke engines.

Mixing ratio: 1:50 (2%).

If Husqvarna two-stroke oil is not available another good quality two-stroke oil can be used.

Mixing ratio: 1:33 (3%) or 1:25 (4%).

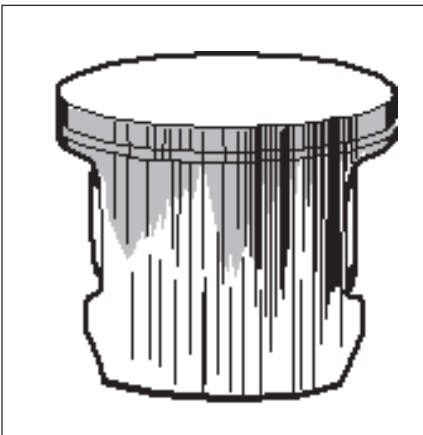

Medium to deep scores on the exhaust side.
The piston ring is stuck in the groove.
Black discoloration under the piston ring due to blow-by.

Piston scoring caused by heavy carbon deposits

Too heavy carbon depositing can cause damage similar to that caused by insufficient lubrication. However, the piston skirt has a darker colour caused by the hot combustion gases that are blown past the piston.

This type of piston damage starts at the exhaust port where carbon deposits can become loose and get trapped between the piston and the cylinder wall.

Typical for this type of piston damage is brown or black discoloration of the piston skirt.

Cause:

- Wrong type of two-stroke oil or petrol.
- Incorrect oil mixture in the petrol.
- Incorrect carburettor setting.

Action:

Change the fuel.
Change to a fuel with the correct oil mixture.
Correct the carburettor setting

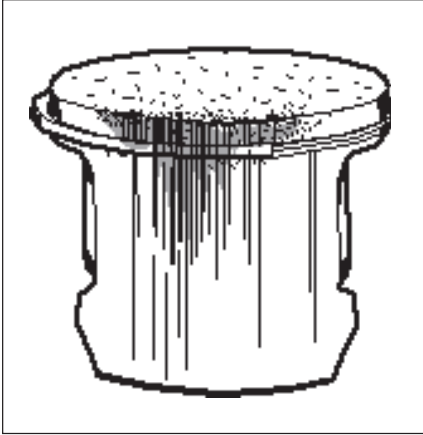

Exhaust side damaged by a broken piston ring. The piston ring parts damage the top section and cause score marks.

Piston damage caused by a too high engine speed.

Typical damage from too high engine speed is ruptured piston ring/piston rings, broken circlip on the gudgeon pin, faulty bearings or that the guide pin for the piston ring has become loose.

Piston ring breakage

A too "lean" carburettor setting results in a too high speed and a high piston temperature. If the piston temperature rises above the normal working temperature the piston ring can seize in its groove, consequently it will not sit deep enough in its groove. The edges of the piston ring can then hit the top edge of the exhaust port and be smashed and also cause piston damage.

A too high engine speed can also cause rapid wear to the piston ring and play in the piston ring groove primarily in front of the exhaust port. The ring is weakened by the wear and can be caught in the port causing serious piston damage.

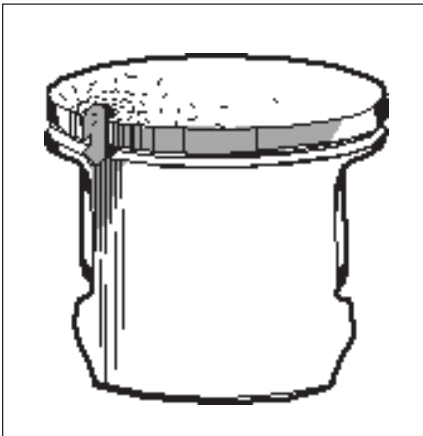

The guide pin for the piston ring has been pushed up through the top of piston.

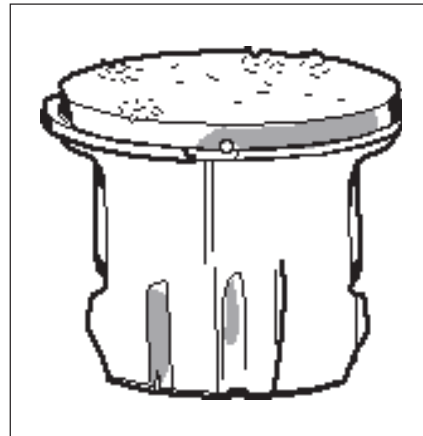

Deep, irregular grooves caused by a loose circlip. Shown here on the piston's inlet side.



Irregular grooves on the piston's inlet side caused by a broken roller retainer.

Piston ring guide pin vibrated loose

A too high engine speed can cause the ends of the piston ring to hammer against the guide pin when the piston ring moves in its groove. The intensive hammering can drive out the pin through the top of the piston causing serious damage also to the cylinder.

Damage caused by gudgeon pin circlips

A too high engine speed can cause the gudgeon pin circlips to vibrate. The circlips are drawn out of their grooves due to the vibrations, which in turn reduces the circlips' tensioning power. The rings can then become loose and damage the piston.

Bearing failure

Failure of the crankshaft bearing or on the connecting rod bearing is usually caused by a too high engine speed, resulting in the bearing being overloaded or overheating. This in turn can cause the bearing rollers or ball to glide instead of rotate, which can cause the roller or ball retainer to break.

The broken debris can be trapped between the piston and cylinder wall, damaging the piston skirt.

Debris can also pass up through the cylinder's transfer channels and cause damage to the top and sides of the piston as well as to the cylinder's combustion chamber.

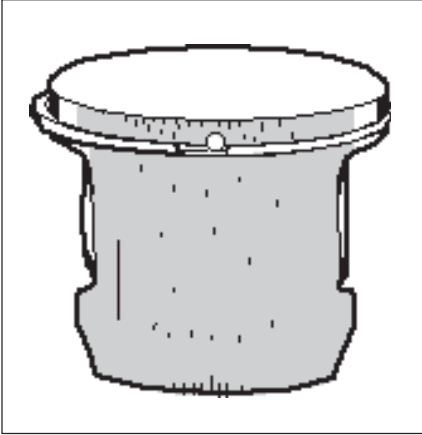

Small score marks and a matt, grey surface on the piston's inlet side caused by fine dust particles.

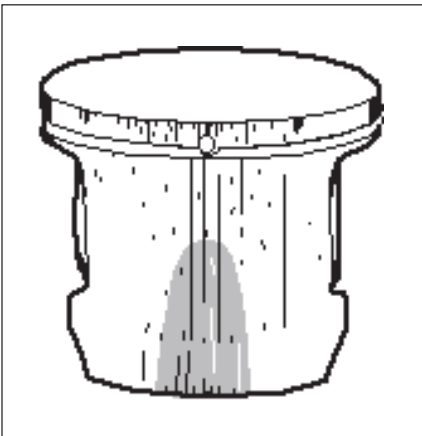

Inlet side.

Particles of dust and dirt from carbon-like deposits on the top of the piston and in the piston ring groove. The piston ring sits firmly in the groove. Piston material has been worn away.

The lower part of the piston skirt is thinner on the inlet side than on the exhaust side.

Foreign objects

Everything other than clean air and pure fuel that enters the engine's inlet port causes some type of abnormal wear or damage to the cylinder and piston.

This type of increased wear shows on the piston's inlet side starting at the lower edge of the piston skirt.

The damage is caused by badly filtered air that passes through the carburettor and into the engine.

Cause:

- Faulty air filter. Small dust particles pass through the filter.
- The filter is worn out due to too much cleaning, whereby small holes have appeared in the material.
- Unsuitable filter maintenance, such as wrong method or wrong cleaning agent. Flock material becomes loose and holes appear.
- Air filter incorrectly fitted.
- Air filter damaged or missing.

Action:

Fit a finer grade filter.

Check the filter carefully for holes and damage after cleaning. Replace the filter if necessary.

Clean more carefully and use the right cleaning agent (such as tepid soapy water). Change the filter.

Fit the filter correctly.

Fit a new air filter.

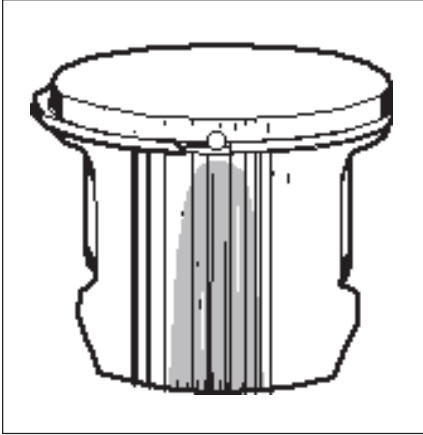

The piston scored and worn from the piston ring down on the inlet side.

Larger, softer particles that penetrate into the engine cause damage to the piston skirt under the piston ring as the illustration shows.

Cause:

- Air filter incorrectly fitted.
- Air filter damaged or missing.

Action:

- Fit the air filter correctly.
- Fit a new air filter.

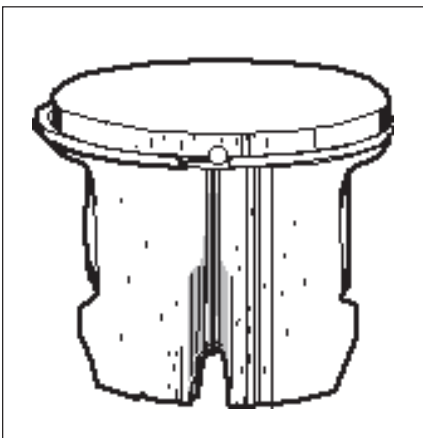

Extensive damage to the lower part of the piston's inlet side.

Larger, harder particles that enter the engine cause serious damage to the underside of the piston skirt.

Cause:

- Air filter damaged or missing.
- Parts from the carburettor or intake system have come loose and entered the engine.

Action:

- Fit a new air filter.
- Regular service and inspection.

Service tips

<p>Defect: Broken cooling fins, damaged threads or sheared bolts by the exhaust port. Seizure marks in the cylinder bore (especially by the exhaust port).</p> <p>Surface coating in the cylinder bore worn out (primarily at the top of the cylinder). The piston shows signs of seizure score marks.</p> <p>Piston ring burnt in its groove.</p> <p>Bolts much too tight in the aluminium material.</p>	<p>Action: In severe cases – replace the cylinder. Repair the threads using Heli-Coil. Polish the damaged area using a fine grade emery cloth so that the coating of aluminium disappears. With deep seizure score marks the piston and cylinder should be replaced. Replace the cylinder and piston.</p> <p>Carefully polish the damaged area using a fine file of fine grade emery cloth. Before the piston is refitted the cylinder should be polished as above. With deep score marks the piston and cylinder should be replaced. Carefully loosen the piston rings and clean the groove well before refitting. Carbon deposits in the groove impair the important heat transfer between the piston and cylinder.</p> <div style="border: 1px solid black; padding: 5px; margin: 10px 0;"> <p>NOTE! Be careful with the lower edge of the piston ring groove. If this is damaged, or if carbon deposits remain, the compression pressure can leak through.</p> </div> <p>Check the wear on the piston ring by placing it in the lower part of the cylinder bore.</p> <p>Position a suitable punch on the bolt head and give a few sharp knocks with a hammer. If the bolt still does not loosen, repeat the procedure.</p>
--	--

Wear tolerances

Cylinder bore

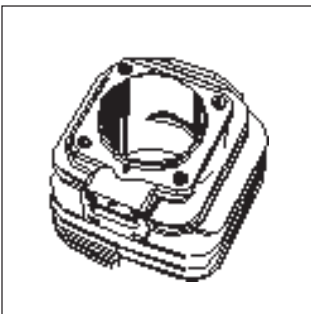

When the surface coating is worn and aluminium appears.

Piston ring gap

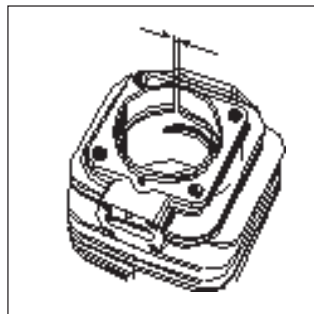

Max. 1.0 mm with the piston ring inserted in the lower part of the cylinder.

Piston ring groove

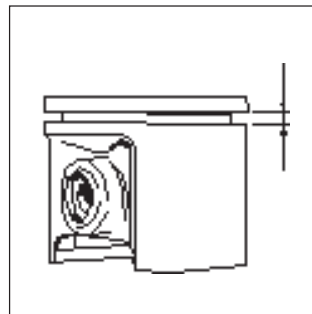

Max. 1.6 mm. Clean the groove before checking the measurement.

Piston ring play

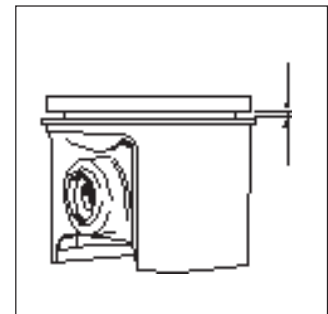

Max. 0.15 mm. Clean the groove before checking the measurement.

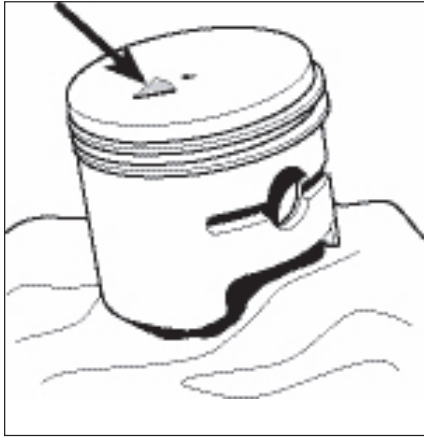

Assembly

Lubricate the gudgeon pin's needle bearing with a few drops of engine oil.

Assembly

Lubricate the gudgeon pin's needle bearing with a few drops of engine oil.

Direct the arrow on the top of the piston towards the exhaust port. Press in the gudgeon pin and fit the circlips.

NOTE!

Place a rag in the crankcase opening to prevent the circlip from falling into the crankcase in case it should fly out.

Do not forget the spacer washers on each side of the piston bolt bearing.

Check that the circlips are properly seated in the grooves.

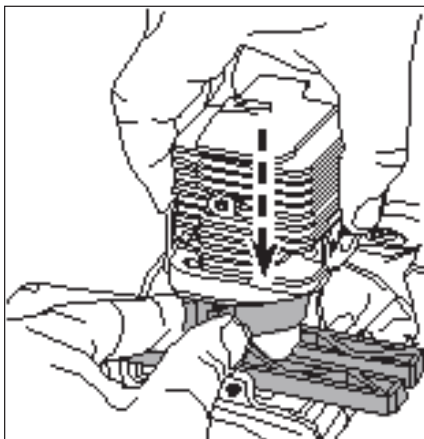

Check that the pulse channel in the cylinder is open.

Assemble the cylinder with the help of assembly set 502 50 70-01.

Check that the pulse channel in the cylinder is open.

Place a new cylinder base gasket on the crankcase. Lubricate the piston and the big-end bearing with a few drops of engine oil.

Assemble the cylinder with the help of the piston ring compressor in the assembly set 502 50 70-01.

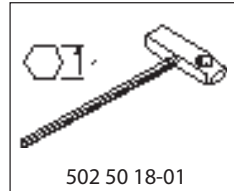
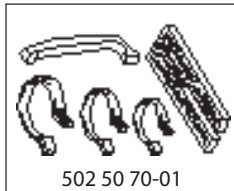

NOTE!

Do not turn the cylinder, as the piston rings can easily be broken.

Tighten the 2 screws diagonally crosswise.

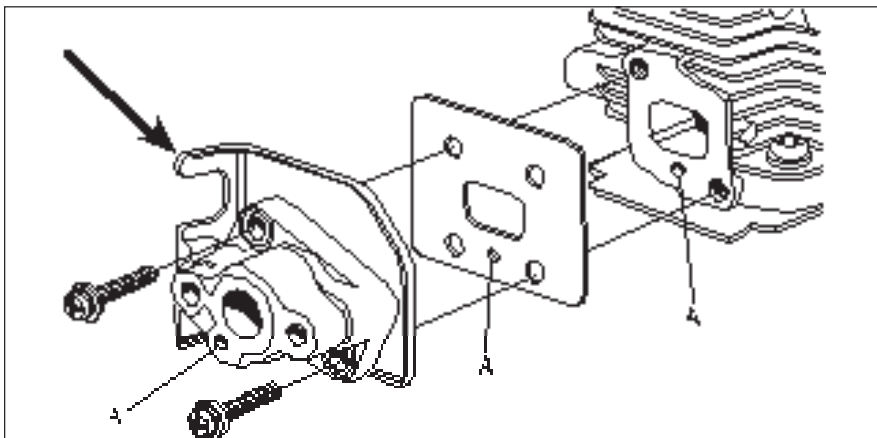

Inspect the distance piece for crack formation or other damage that may result in leakage, which in turn can cause uneven idling and starting difficulties.

Check that the impulse channel (A) is open.

Assemble the remaining parts in the reverse order as set out for dismantling. See respective sections in the manual.

Crankshaft and crankcase

7

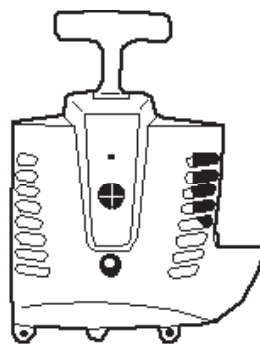

Contents

Dismantling _____	48
Inspecting the crankshaft _____	49
Assembly _____	50

The task of the crankshaft is to transform the reciprocating motion of the piston to rotation. This requires a stable design withstanding immense pressure and rotational and bending strain, as well as high rotational speed. In addition the connecting rod is exposed to large acceleration and retardation forces as it moves between the top and bottom dead centres. This puts special demands on the bearings that must withstand quick changes in load. Moreover, the bearing's roller retainer must also cope with high temperatures and friction. It is therefore extremely important when servicing to check the roller retainer for cracks, wear and discolouration caused by overheating.

The crankshaft is journalled in the crankcase on heavy-duty ball bearings. In addition to the journalling point for the crankshaft, the crankcase acts as a scavenging pump for the fuel/air mixture when this is "sucked" from the carburettor and is forced into the cylinder's combustion chamber. The crankcase must be perfectly sealed so as not to affect this pump function. There cannot be any leakage from the crankshaft, between the crankcase halves or between the crankcase and the cylinder.

Always replace the sealing rings and gaskets when servicing the crankcase.

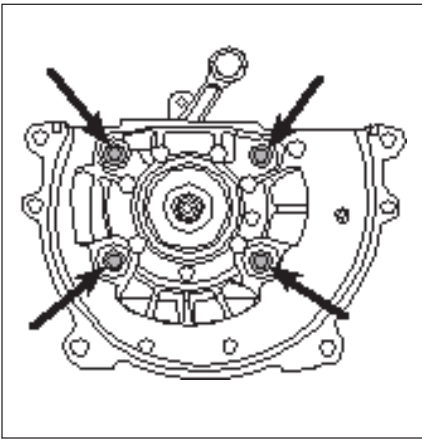

Dismantling

Dismantle all components so that only the crankcase and crankshaft remain.

Remove the 4 crankcase screws.

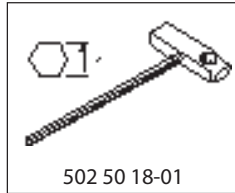

502 50 18-01

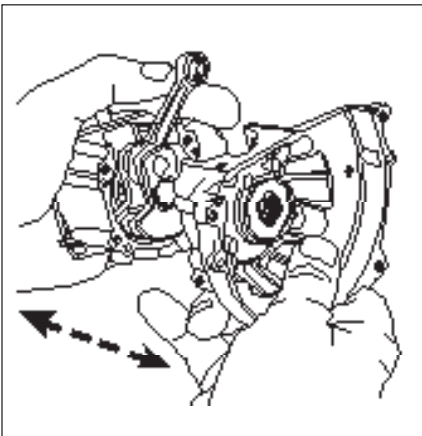

Separate the crankcase halves.



Lift out the crankshaft.

Remove the crankcase gasket.

Dismantling

Dismantle all components so that only the crankcase and crankshaft remain.

See the respective sections for detailed information if necessary.

Remove the key for the flywheel.

Dismantle the 4 screws holding the crankcase halves together.

Separate the crankcase halves (a special tool is not required).

The crankshaft has a snug fit in the crankshaft bearing.

Lift the crankshaft out of the crankcase half on the starter side (a special tool is not required).

Remove the crankcase gasket.

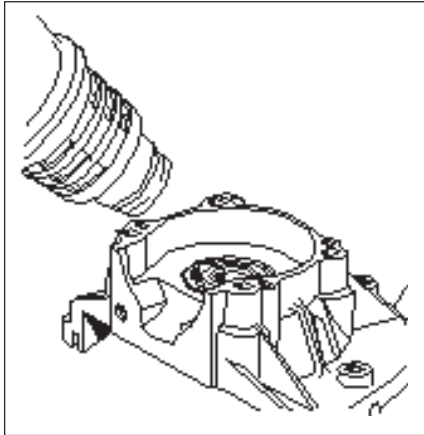

Dismantle the ball-bearings from the crankcase halves.

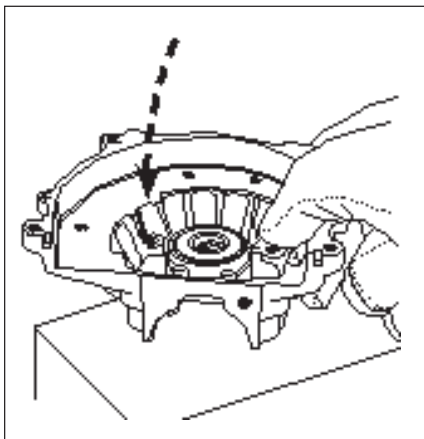

Knock the crankcase half against a wooden block so that the ball-bearing falls out.

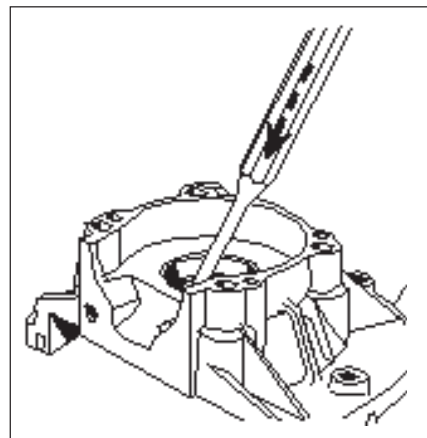
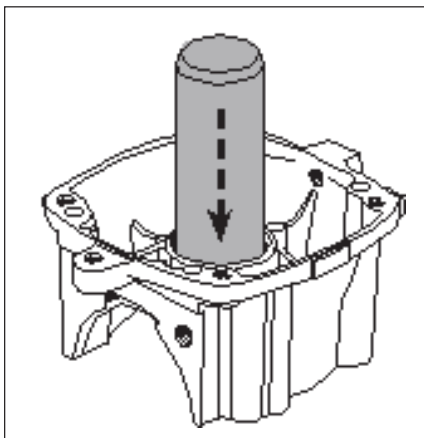

Dismantle the ball-bearings from the crankcase halves.

Heat the crankcase halves to 120°C using a hot air gun.

Knock the crankcase half against a wooden block so that the ball-bearing falls out.

Dismantle the sealing rings from the crankcase halves.

Use a suitable punch or sleeve and knock out the sealing rings with the help of a hammer. Do this while the crankcase half is still warm if possible.

NOTE!

The bearing seating in the crankcase half of the flywheel side is divided by a circlip.

Now clean the crankcase halves and crankshaft.

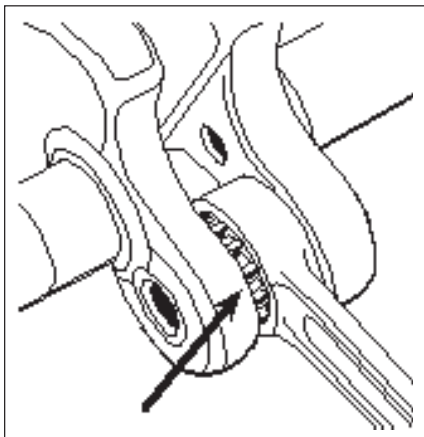

Inspecting the crankshaft

Inspect the large end of the connecting rod.

Inspecting the crankshaft

The crankshaft cannot be reconditioned but must be replaced if it is worn or damaged.

Inspect the large end of the connecting rod. If seizure marks, discolouration on the sides or damaged needle holders are found the crankshaft must be replaced.

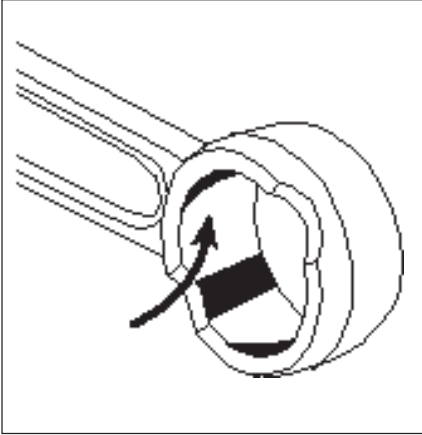

Inspect the small end of the connecting rod.

Inspect the small end of the connecting rod.

If seizure marks or discolouration are found in the bearing track the crankshaft must be replaced.

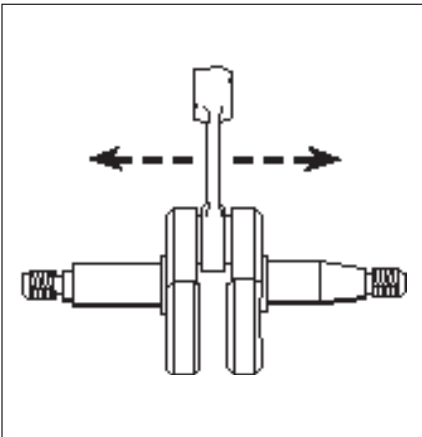

Check the crank bearing.

Check the crank bearing. The connecting rod shall not have any radial play (up and down).

It should, however, have axial play, in order to ensure good lubrication of the crank bearing among other things.

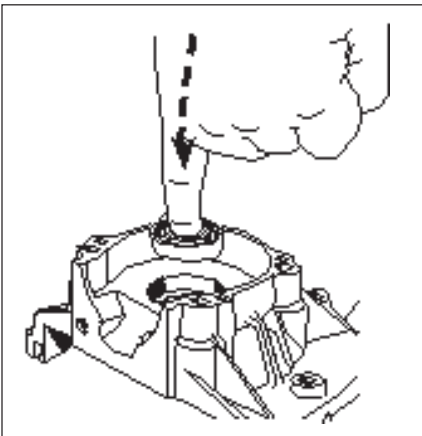

Assembly

Mount the bearings in the crankcase halves.

Assembly

Mount the bearings in the crankcase halves.

Heat the crankcase halves to approx. 110°C using a hot air gun. Put the ball-bearings in position.

Use a suitable punch and hammer, if needed.

Make sure the bearing rests against the circlip and shoulder in the bearing seating.

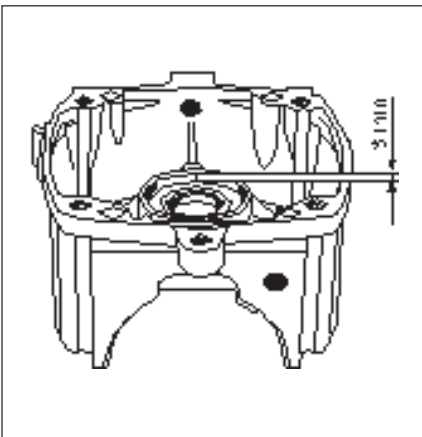

Fit the sealing rings in the crankcase halves.

Fit the sealing rings in the crankcase halves with the help of a suitable punch.

Turn the sealing rings so the abraded edge faces inwards.

The sealing ring on the clutch side should be placed 3 mm below the edge of the bearing seating but flush with the crankcase on the flywheel side.

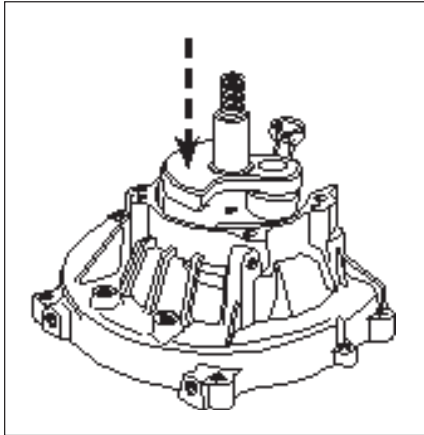

Fit the crankshaft in the crankcase half on the flywheel side.

Fit the crankshaft in the crankcase half on the flywheel side. Lubricate the stub axle with a few drops of oil and carefully slide the crankshaft into the bearing.

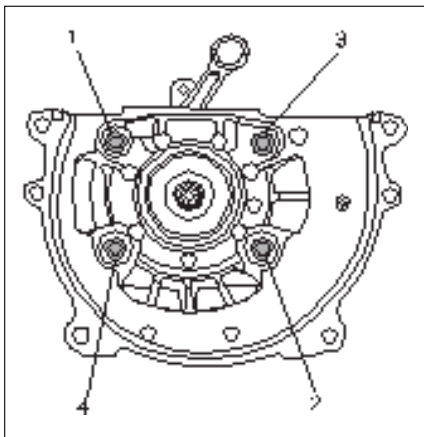

Place a new crankcase gasket in position. Fit the crankcase half on the starter side. Tighten the 4 crankcase screws cross-wise.

Check that the 3 guide sleeves are in their place in the crankcase half of the starter side.

Place a new crankcase gasket on the crankcase and secure if necessary with a little grease.

Lubricate the crankshaft journal with a few drops of oil and slide the crankcase half on the starter side into position.

Tighten the 4 crankcase screws crosswise a little at a time.

Check that the crankshaft can rotate easily.

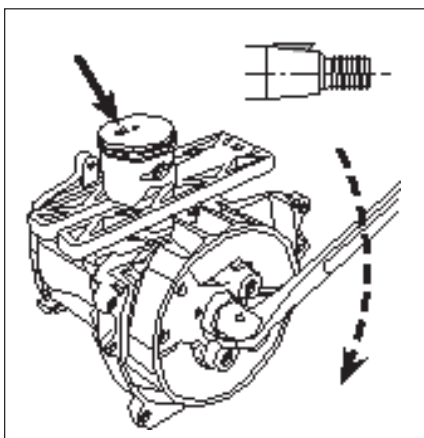

Assemble the piston. Attach the flywheel.

Position the cylinder base gasket.

Assemble the piston on the connecting rod.

Check that the piston is turned so the arrow points towards the exhaust port.

Do not forget the spacers between the piston and the needle bearing!

Make sure that the gudgeon pin circlips are seated correctly in the slots.

Place the flywheel key in position in the crankcase keyway so that the flat surface is parallel to the centre line of the crankshaft.

Attach the flywheel.



Assemble the cylinder.

Lubricate the piston and piston rings with a few drops of oil.

Assemble the cylinder.

Use the piston ring compressor and carefully slide the cylinder into position.

Tighten the 2 screws.

Assemble the remaining parts in the reverse order as set out for dismantling.

See relevant sections in the manual.

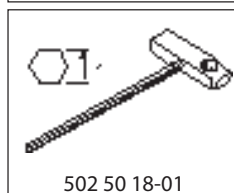
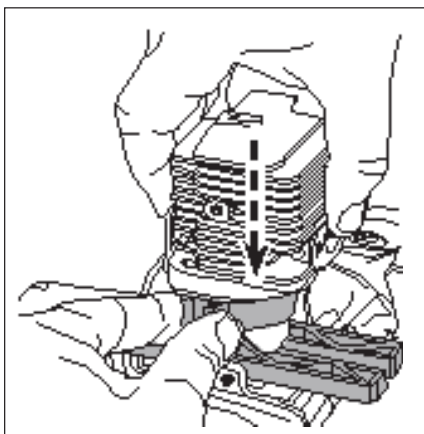

Tools



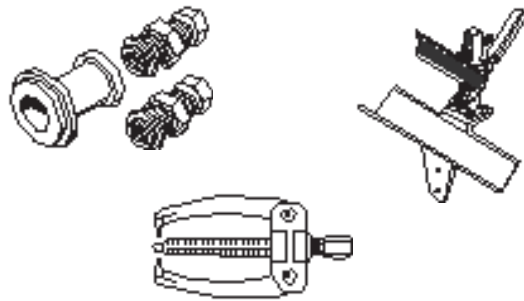









8

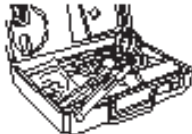
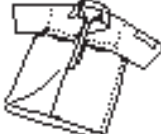

Contents

Starter	54
Electrical system	54
Fuel system	54
Centrifugal clutch	54
Angle gear	55
Cylinder and piston	55
Crankshaft and crankcase	55
Workshop equipment	55

Starter	Electrical system	Fuel system	Fuel system	Centrifugal clutch
 522 43 18-01	 502 71 13-01	 505 69 85-70	 502 71 14-01	 502 50 18-01
	 502 50 19-01	 531 00 60-76		 522 43 18-01
	 502 50 06-01	 531 03 06-23		
	 502 50 18-01	 502 50 83-01		
	 522 43 18-01	 502 02 61-02		
	 510 13 89-01	 501 60 02-03		
	 502 51 34-02			

Angle gear	Cylinder and piston	Crankshaft and crankcase	Workshop equipment	Workshop equipment
 <p>502 50 18-01</p>	 <p>502 50 18-01</p>	 <p>502 50 18-01</p>	 <p>502 51 03-01</p>	 <p>544 13 05-01</p>
 <p>503 97 64-01</p>	 <p>505 38 17-05</p>	 <p>502 50 70-01</p>	 <p>531 03 06-23</p>	 <p>544 13 08-01</p>
 <p>505 38 17-09</p>	 <p>502 50 70-01</p>		 <p>502 71 14-01</p>	 <p>544 13 09-01</p>
	 <p>502 50 19-01</p>		 <p>505 69 85-70</p>	 <p>544 13 10-01</p>
				 <p>544 34 87-01</p>

Technical data

9

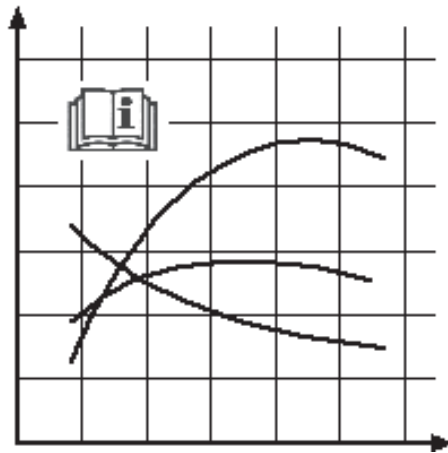

Contents

Engine	58
Ignition system	58
Carburettor	58
Clutch	58
Driving	58
Dimensions	58

Engine

Displacement, cm ³	25.4
Cylinder bore, mm	34.0
Stroke, mm	28.0
Max output, kW / speed, rpm	0.8 / 7500

Ignition system

Manufacturer	IKEDA Denso
Spark plug, NGK	BPMR7A
Spark plug, electrode gap, mm	0,6
Max. speed, rpm	11500

Carburettor

Manufacturer	Walbro WYK
Basic setting H-needle, turns	1 1/2
Idle speed, rpm	2.500
Air filter type	Foam plastic
Throttle control, type	Forefinger
Fuel consumption	720 g / kWh

Clutch

2-shoe clutch. Diameter, mm	53.5
Engage speed, rpm	3.300

Driving

Angle gear, degrees	30
Angle gear, gear ratio	1:1,46
Control drive disc, inch	1
Shaft diameter, mm	24
Drive axle diameter, mm	7
Drive axle connections	Splines / splines

Dimensions

Weight, kg	5.1
Tank volume, litres	0.75



www.husqvarna.com

11 535 83-26

2018W35